



AITMANOS

ZELLIGE  
CASABLANCA

Maison Aït Manos



# COLLECTIONS



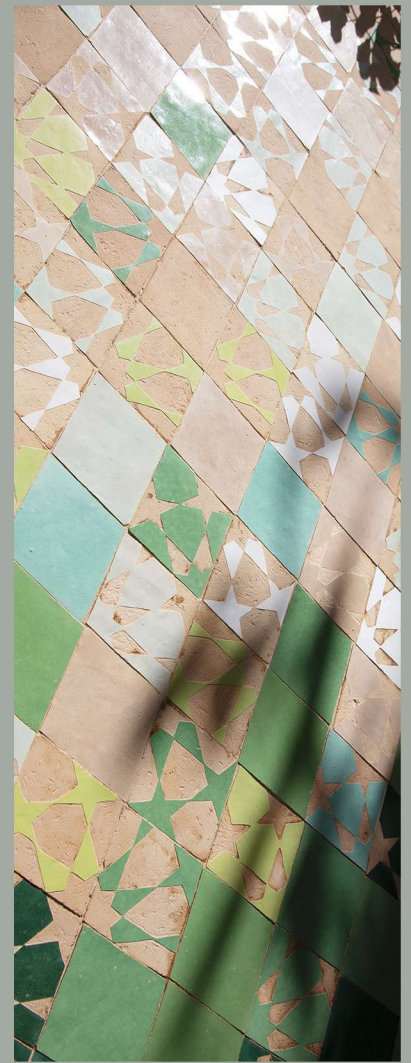

## *THE ESSENTIALS*

Versatile and flexible, "the Essentials" collection makes it possible to adapt to all styles, whether modern or traditional.

A timeless collection, Basic presents various stylistic proposals to complement, sublimate and finalize all spaces. Floor or wall tiles in monochromatic hues ranging from beige to red, the Basic collection is the foundation of an inspired and unique décor.

## *THE CLASSICS*

"The Classics" collection itemizes all of the essential patterns of Moroccan zellige.

Deeply rooted in Moroccan architectural heritage, these patterns, such as the iconic "Oulmes" are revisited by Aït Manos to build spaces that hint at Moroccan tradition whilst keeping a contemporary character. As such, as much as they are sometimes commonly used in their original versions, other times they are revisited in monochromatic hues in the heart of the Aït Manos Workshops, resulting in a unique and singular décor.

## *THE DESIGNS*

To transpose traditional Moroccan know-how and graphic art in current spaces all around the world, Aït Manos designed modern patterns.

A line where handmade traditional Moroccan ceramic tiles transforms into powerfully avant-garde decorative elements. Preserving the purity of tradition and going for a subtle color scheme that borders minimalism, "The designs" collection blends into spaces where volumes and lights stand out from those encountered in Morocco.

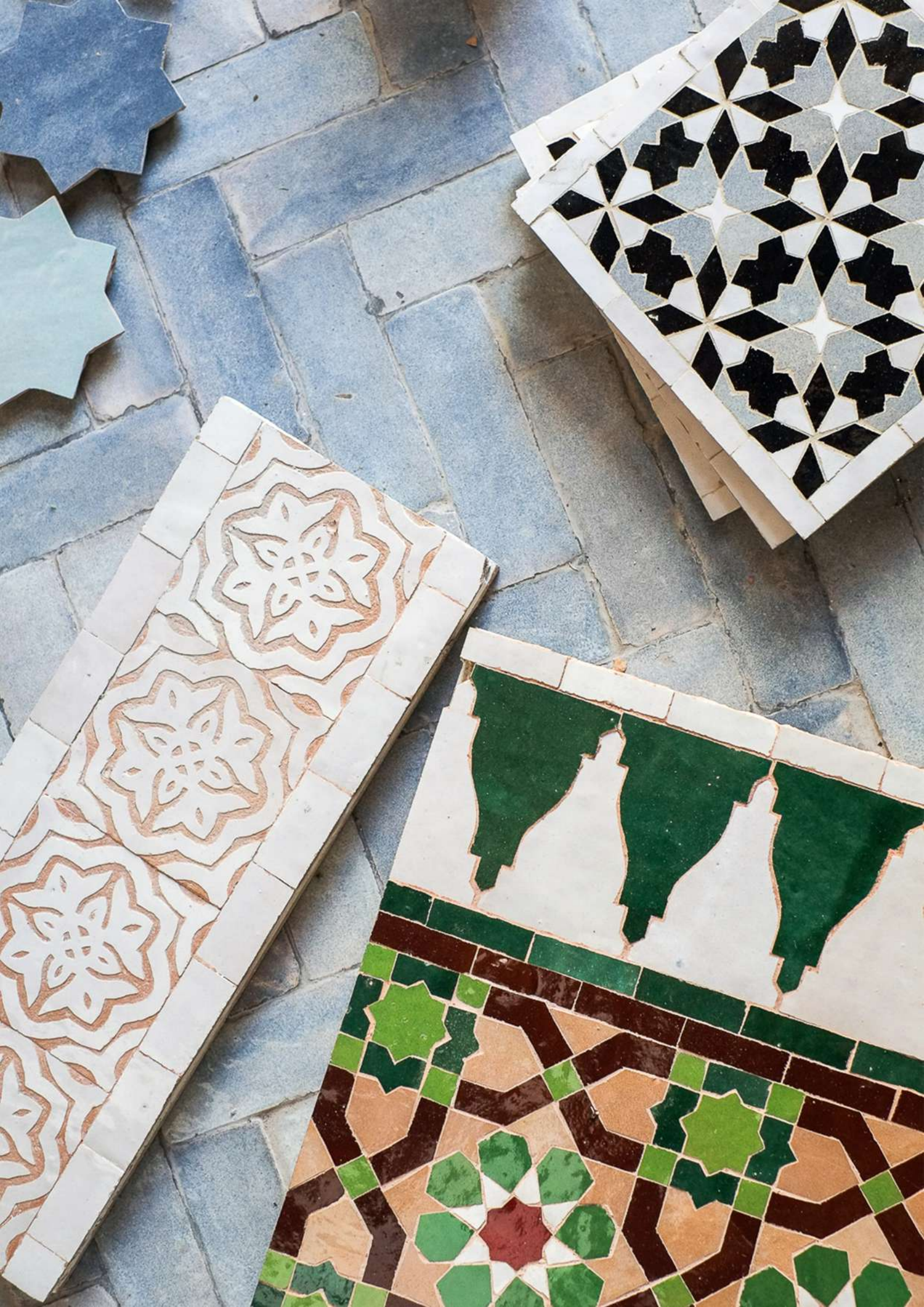

*THE ESSENTIALS*

---

Patterns

Sahara

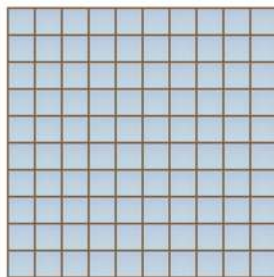
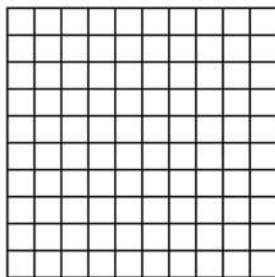

30 x 30 cm  
0.09 m<sup>2</sup> 11 PL / 1m<sup>2</sup>

11<sup>13/16</sup> x 11<sup>13/16</sup> inch  
1Pc = 1Sqft

Guéliz

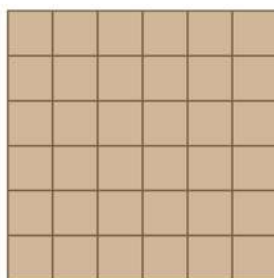
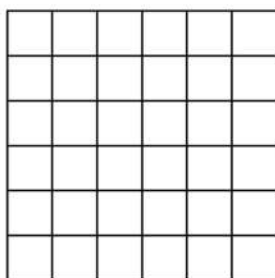

30 x 30 cm  
0.09 m<sup>2</sup> 11 PL / 1m<sup>2</sup>

11<sup>13/16</sup> x 11<sup>13/16</sup> inch  
1Pc = 1Sqft

Ait Manos

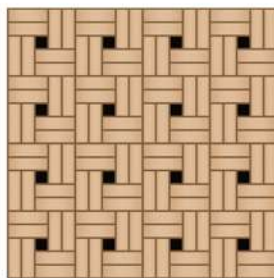
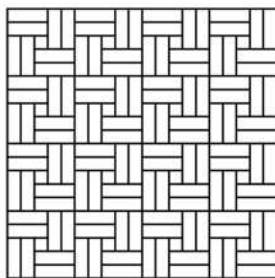

30 x 30 cm  
0.09 m<sup>2</sup> 11 PL / 1m<sup>2</sup>

11<sup>13/16</sup> x 11<sup>13/16</sup> inch  
1Pc = 1Sqft

Ait Manos Bis

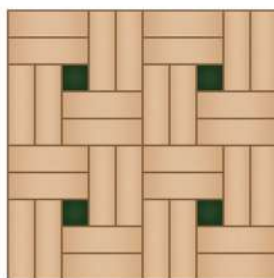
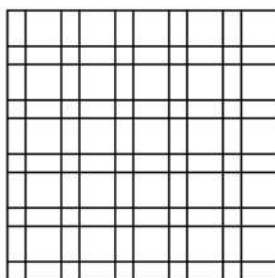

30 x 30 cm  
0.09 m<sup>2</sup> 11 PL / 1m<sup>2</sup>

11<sup>13/16</sup> x 11<sup>13/16</sup> inch  
1Pc = 1Sqft

Damier

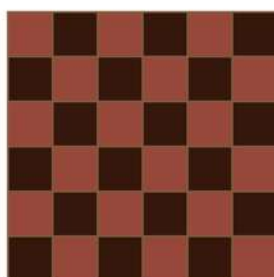
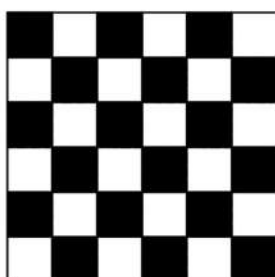

30 x 30 cm  
0.09 m<sup>2</sup> 11 PL / 1m<sup>2</sup>

11<sup>13/16</sup> x 11<sup>13/16</sup> inch  
1Pc = 1Sqft



Kerouna

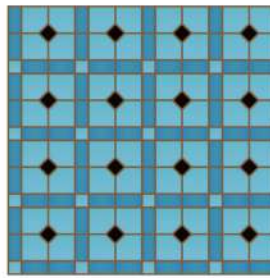
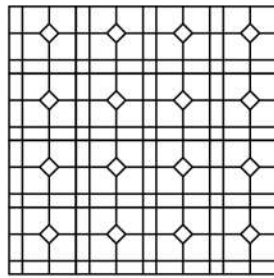

30 x 30 cm  
0.09 m<sup>2</sup> 11 PL / 1m<sup>2</sup>

11<sup>13/16</sup> x 11<sup>13/16</sup> inch  
1Pc = 1Sqft

Mogador

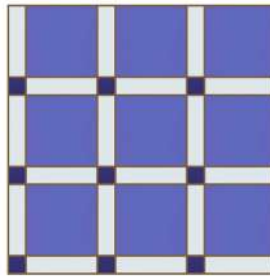
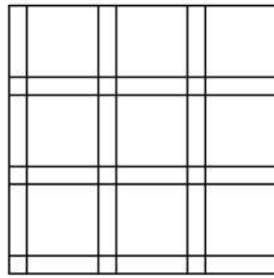

30 x 30 cm  
0.09 m<sup>2</sup> 11 PL / 1m<sup>2</sup>

11<sup>13/16</sup> x 11<sup>13/16</sup> inch  
1Pc = 1Sqft

Mansour

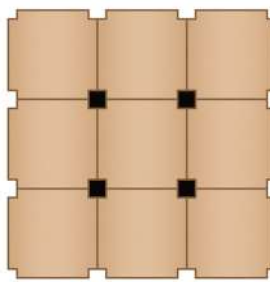
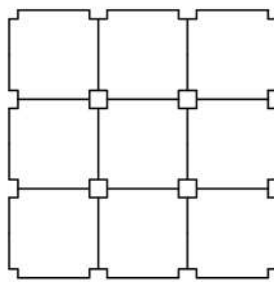

30 x 30 cm  
0.09 m<sup>2</sup> 11 PL / 1m<sup>2</sup>

11<sup>13/16</sup> x 11<sup>13/16</sup> inch  
1Pc = 1Sqft

Grenada

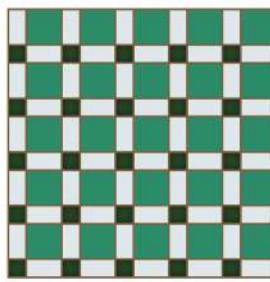
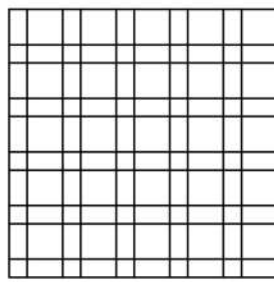

30 x 30 cm  
0.09 m<sup>2</sup> 11 PL / 1m<sup>2</sup>

11<sup>13/16</sup> x 11<sup>13/16</sup> inch  
1Pc = 1Sqft

Grenada Bis

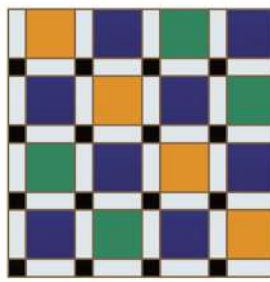
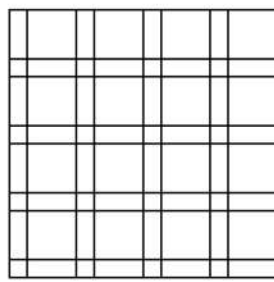

30 x 30 cm  
0.09 m<sup>2</sup> 11 PL / 1m<sup>2</sup>

11<sup>13/16</sup> x 11<sup>13/16</sup> inch  
1Pc = 1Sqft



Sefrou

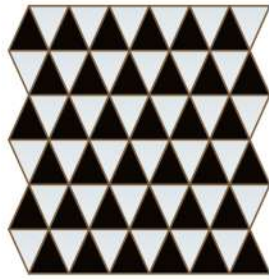
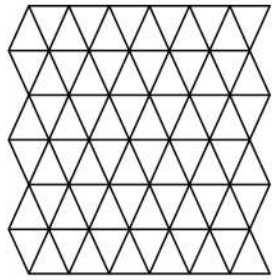

27 x 27 cm  
0.081 m<sup>2</sup> 13 PL / 1m<sup>2</sup>

10<sup>5/8</sup> x 11<sup>13/16</sup> inch  
1Pc = 0.9 Sqft

Saïdia

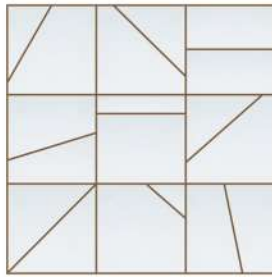
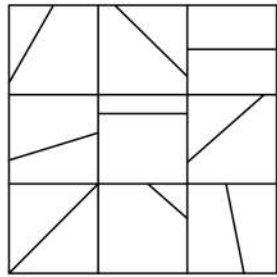

30 x 30 cm  
0.09 m<sup>2</sup> 11 PL / 1m<sup>2</sup>

11<sup>13/16</sup> x 11<sup>13/16</sup> inch  
1Pc = 1Sqft

Tangier

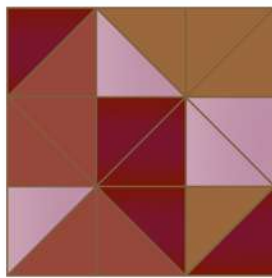
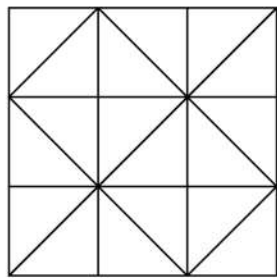

30 x 30 cm  
0.09 m<sup>2</sup> 11 PL / 1m<sup>2</sup>

11<sup>13/16</sup> x 11<sup>13/16</sup> inch  
1Pc = 1Sqft

Tangier Bis

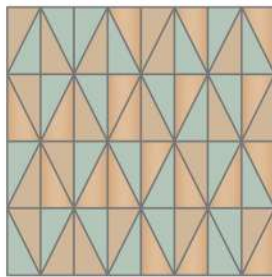
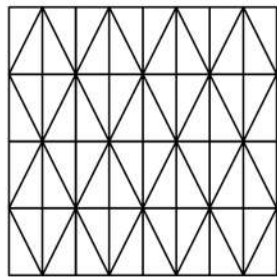

30 x 30 cm  
0.09 m<sup>2</sup> 11 PL / 1m<sup>2</sup>

11<sup>13/16</sup> x 11<sup>13/16</sup> inch  
1Pc = 1Sqft

Talet

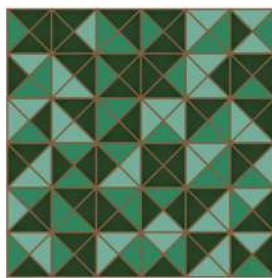
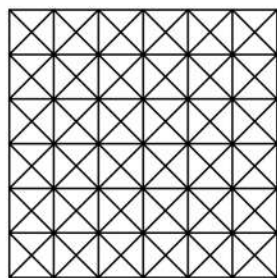

30 x 30 cm  
0.09 m<sup>2</sup> 11 PL / 1m<sup>2</sup>

11<sup>13/16</sup> x 11<sup>13/16</sup> inch  
1Pc = 1Sqft



Boumia

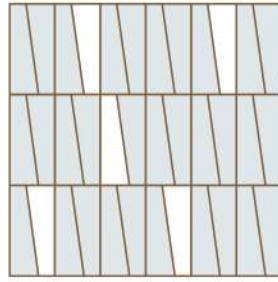
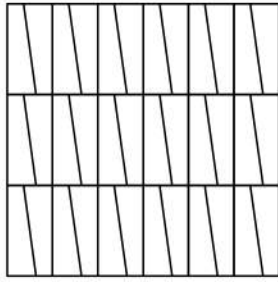

30 x 30 cm  
0.09 m<sup>2</sup> 11 PL / 1m<sup>2</sup>

11<sup>13/16</sup> x 11<sup>13/16</sup> inch  
1Pc = 1Sqft

Mehdia

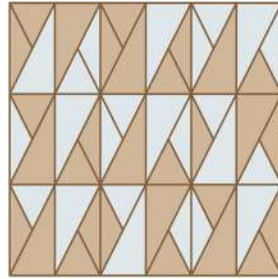
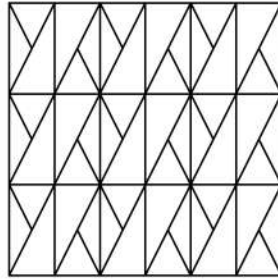

30 x 30 cm  
0.09 m<sup>2</sup> 11 PL / 1m<sup>2</sup>

11<sup>13/16</sup> x 11<sup>13/16</sup> inch  
1Pc = 1Sqft

Module-A

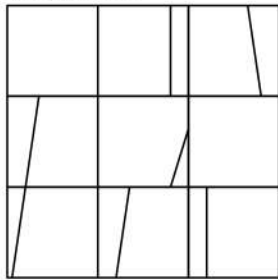

Module-B

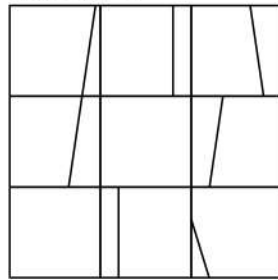

30 x 30 cm  
0.09 m<sup>2</sup> 11 PL / 1m<sup>2</sup>

Volubilis

Module-A

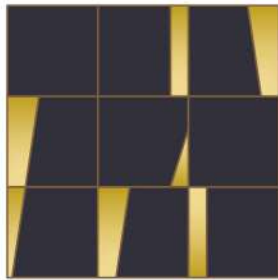

Module-B



11<sup>13/16</sup> x 11<sup>13/16</sup> inch  
1Pc = 1Sqft

Zaio

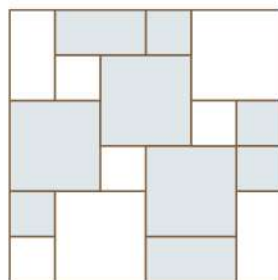
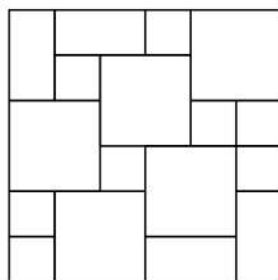

30 x 30 cm  
0.09 m<sup>2</sup> 11 PL / 1m<sup>2</sup>

11<sup>13/16</sup> x 11<sup>13/16</sup> inch  
1Pc = 1Sqft





Almas Diamond

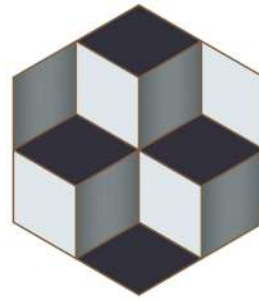
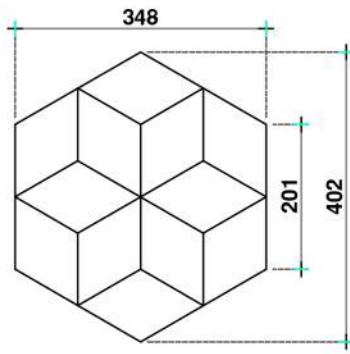

33.5 x 29 cm  
0.073 m<sup>2</sup> 14 PL / 1m<sup>2</sup>

13<sup>3/16</sup> x 11<sup>27/64</sup> inch  
1Pc = 0.79 Sqft

Almas Diamond  
In Rods

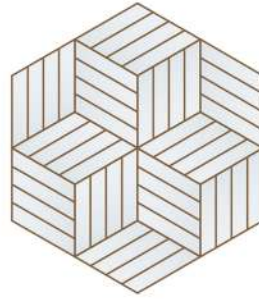
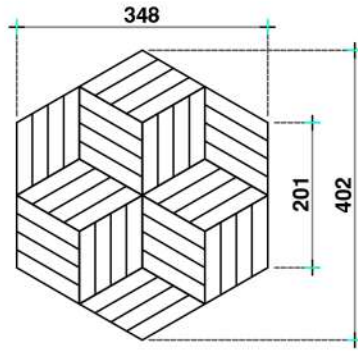

33.5 x 29 cm  
0.073 m<sup>2</sup> 14 PL / 1m<sup>2</sup>

13<sup>3/16</sup> x 11 inch  
1Pc = 0.79 Sqft

Almas Diamond  
Bis

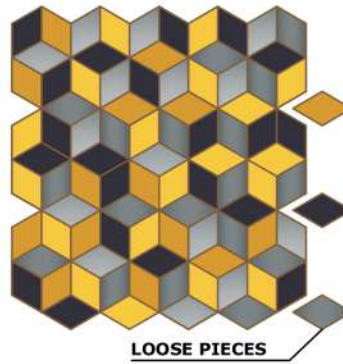
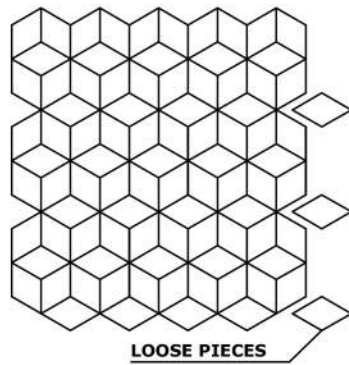

37.3 x 34 cm  
0.12 m<sup>2</sup> 8.3 PL / 1m<sup>2</sup>

14<sup>1/16</sup> x 13<sup>25/64</sup> inch  
1Pc = 1.29 Sqft

Itzer

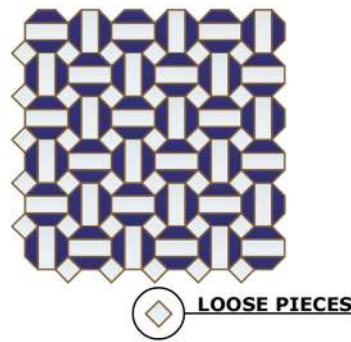
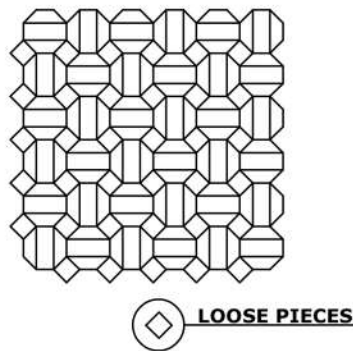

30 x 30 cm  
0.09 m<sup>2</sup> 11 PL / 1m<sup>2</sup>

11<sup>13/16</sup> x 11<sup>13/16</sup> inch  
1Pc = 1Sqft

Itzer Bis

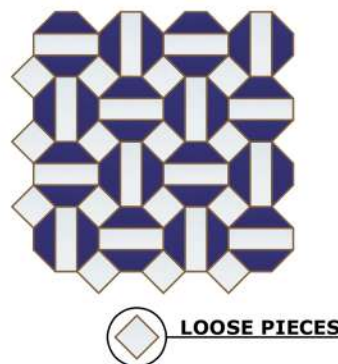
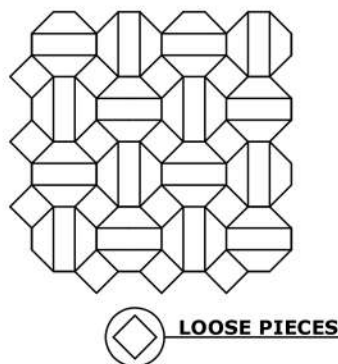

30 x 30 cm  
0.09 m<sup>2</sup> 11 PL / 1m<sup>2</sup>

11<sup>13/16</sup> x 11<sup>13/16</sup> inch  
1Pc = 1Sqft

Dakhla

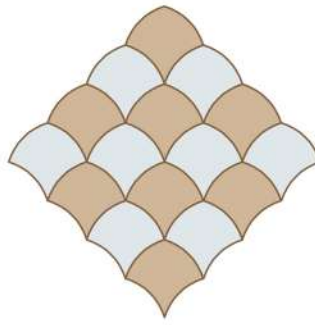
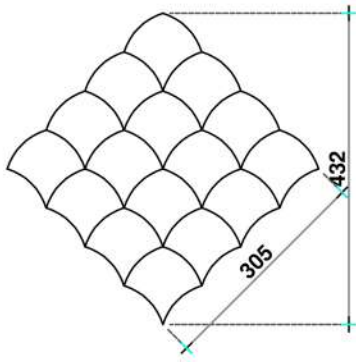

28.3 x 28.3 cm  
0.08 m<sup>2</sup> 13 PL / 1m<sup>2</sup>

11<sup>064</sup> x 11<sup>064</sup> inch  
1Pc = 0.86Sqft

Issafen

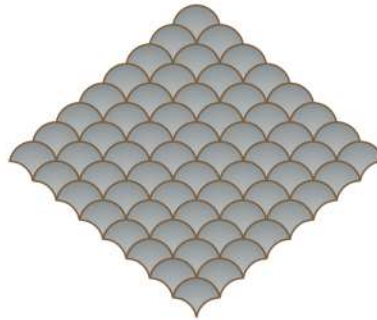
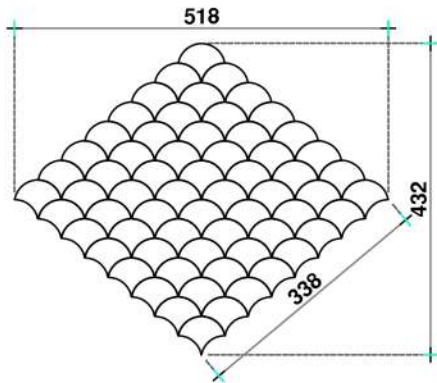

48 x 40 cm  
0.096 m<sup>2</sup> 11 PL / 1m<sup>2</sup>

18<sup>3032</sup> x 15<sup>34</sup> inch  
1Pc = 1Sqft

Arlequin

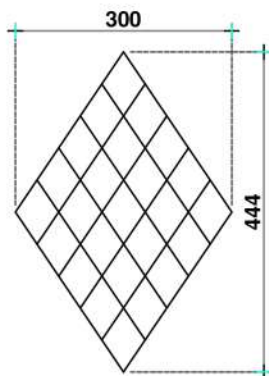

37 x 25 cm  
0.463 m<sup>2</sup> 22 PL / 1m<sup>2</sup>

14<sup>916</sup> x 9<sup>2702</sup> inch  
1Pc = 0.5 Sqft

Meknes

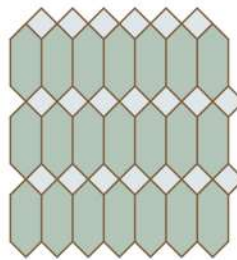
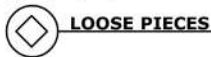
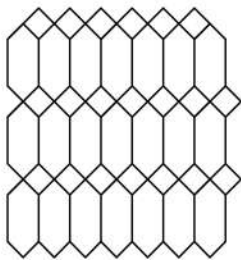

28 x 30 cm  
0.084 m<sup>2</sup> 12 PL / 1m<sup>2</sup>

11<sup>13</sup> x 11<sup>1316</sup> inch  
1Pc = 1Sqft

Zenata

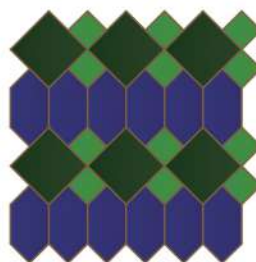
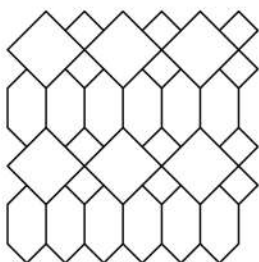

29.7 x 29.7 cm  
0.089 m<sup>2</sup> 12 PL / 1m<sup>2</sup>

11<sup>1116</sup> x 11<sup>1116</sup> inch  
1Pc = 1Sqft

Guércif

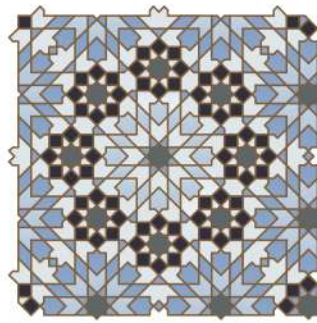
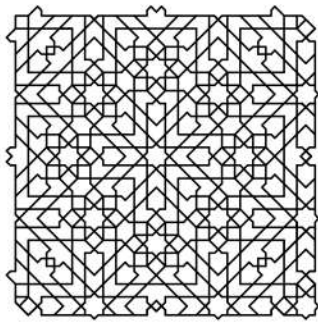

 **LOOSE PIECES**

 **LOOSE PIECES**

33 x 33 cm  
0.109 m<sup>2</sup> 10 PL / 1m<sup>2</sup>

13 x 13 inch  
1Pc = 1.2 Sqft

Jasmin

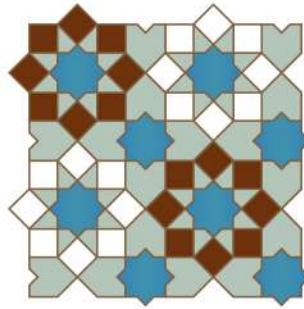
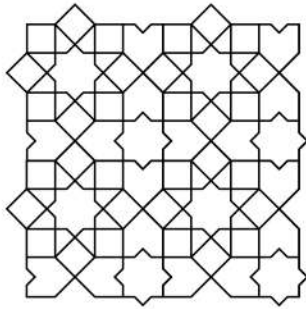

30 x 30 cm  
0.09 m<sup>2</sup> 11 PL / 1m<sup>2</sup>

11<sup>13/16</sup> x 11<sup>13/16</sup> inch  
1Pc = 1Sqft

Taza

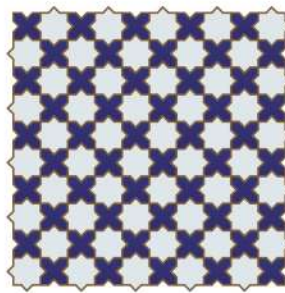
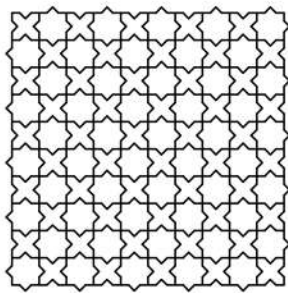

30 x 30 cm  
0.09 m<sup>2</sup> 11 PL / 1m<sup>2</sup>

11<sup>13/16</sup> x 11<sup>13/16</sup> inch  
1Pc = 1Sqft

Malak

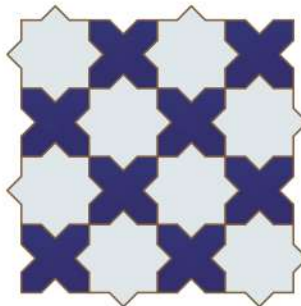
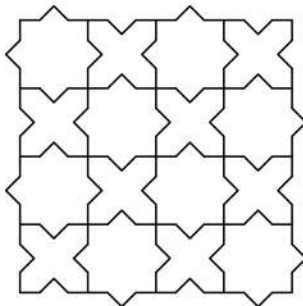

30 x 30 cm  
0.09 m<sup>2</sup> 11 PL / 1m<sup>2</sup>

11<sup>13/16</sup> x 11<sup>13/16</sup> inch  
1Pc = 1Sqft

Skoura

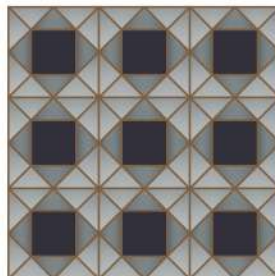
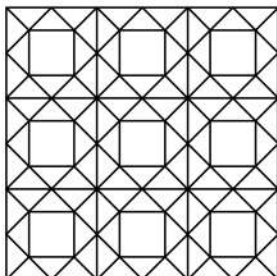

30 x 30 cm  
0.09 m<sup>2</sup> 11 PL / 1m<sup>2</sup>

11<sup>13/16</sup> x 11<sup>13/16</sup> inch  
1Pc = 1Sqft



Mazagan

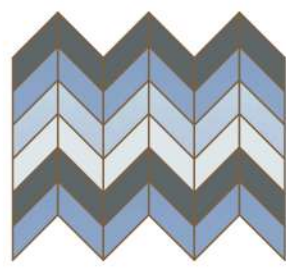
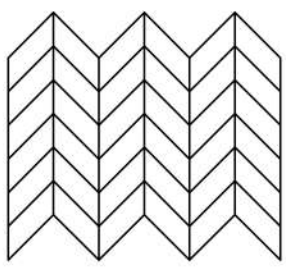

22.3 x 30 cm  
0.067 m<sup>2</sup> 15 PL / 1m<sup>2</sup>

8<sup>25/32</sup> x 11<sup>13/16</sup> inch  
1Pc = 0.7 Sqft

Mazagan Bis

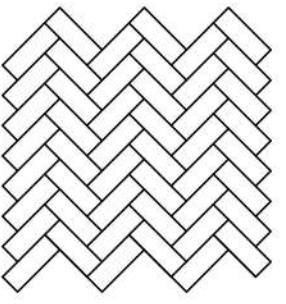

27.9 x 26.7 cm  
0.075 m<sup>2</sup> 13.5 PL / 1m<sup>2</sup>

10<sup>63/64</sup> x 10<sup>33/64</sup> inch  
1Pc = 0.80 Sqft

Fares

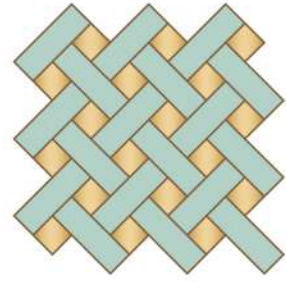
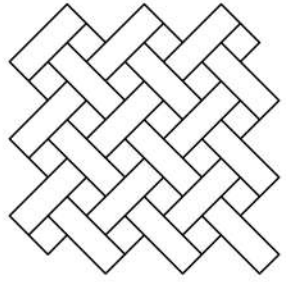

25.5 x 25.5 cm  
0.065 m<sup>2</sup> 16 PL / 1m<sup>2</sup>

10<sup>1/16</sup> x 10<sup>1/16</sup> inch  
1Pc = 0.7 Sqft

Taroudant

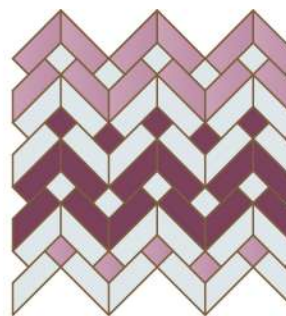
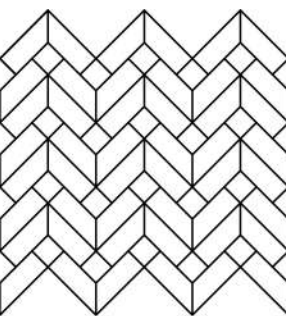

32 x 28.3 cm  
0.09 m<sup>2</sup> 11 PL / 1m<sup>2</sup>

12<sup>19/32</sup> x 11<sup>1/8</sup> inch  
1Pc = 1Sqft

Saïs

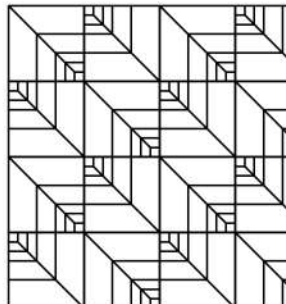

40 x 40 cm  
0.16 m<sup>2</sup> 6.25 PL / 1m<sup>2</sup>

15<sup>3/4</sup> x 15<sup>3/4</sup> inch  
1Pc = 1.72 Sqft



Merzouga

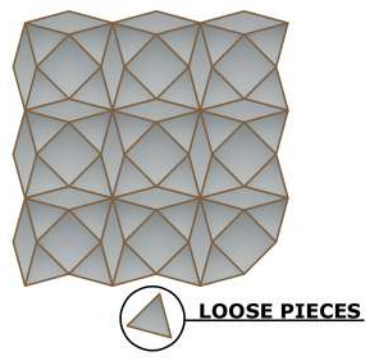
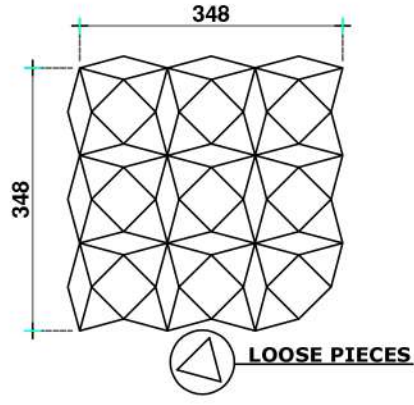

29 x 29 cm  
0.084 m<sup>2</sup> 12 PL / 1m<sup>2</sup>

11<sup>27/64</sup> x 11<sup>27/64</sup> inch  
1Pc = 1Sqft

Ourika

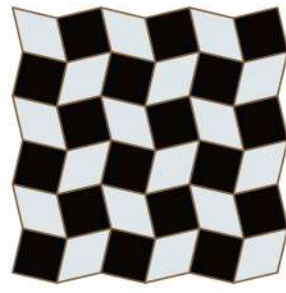
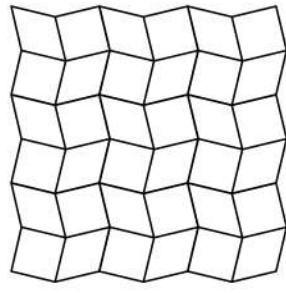

29.2 x 29.2 cm  
0.085 m<sup>2</sup> 12 PL / 1m<sup>2</sup>

11<sup>1/2</sup> x 11<sup>1/2</sup> inch  
1Pc = 1Sqft

Benzou

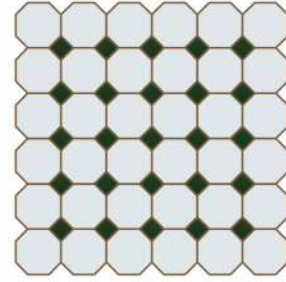
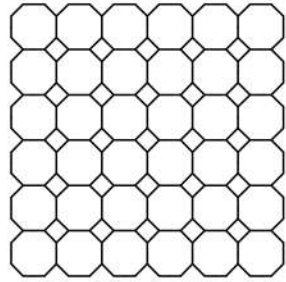

30 x 30 cm  
0.09 m<sup>2</sup> 11 PL / 1m<sup>2</sup>

11<sup>13/16</sup> x 11<sup>13/16</sup> inch  
1Pc = 1Sqft

Paris

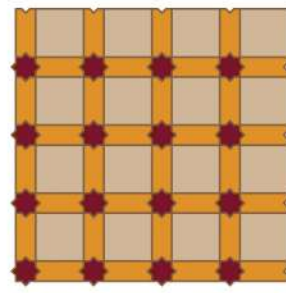
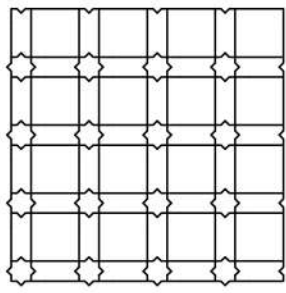

30 x 30 cm  
0.09 m<sup>2</sup> 11 PL / 1m<sup>2</sup>

11<sup>13/16</sup> x 11<sup>13/16</sup> inch  
1Pc = 1Sqft

Erfoud

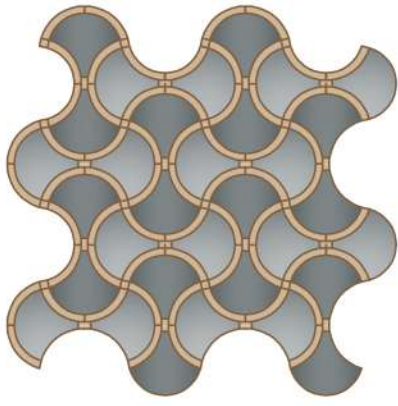
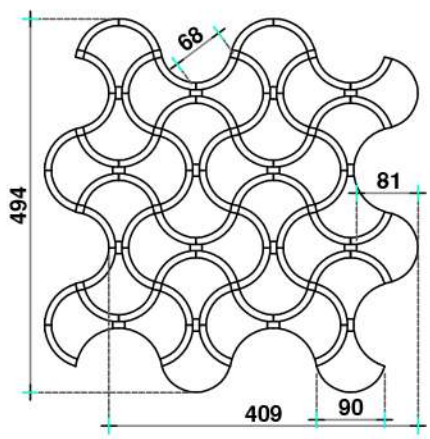

42.6 x 42.6 cm  
0.1815 m<sup>2</sup> 5.5 PL / 1m<sup>2</sup>

16<sup>49/64</sup> x 16<sup>49/64</sup> inch  
1Pc = 1.96 Sqft



# El mansouria

Module-A

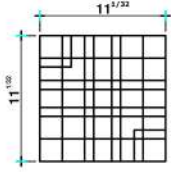

Module-A

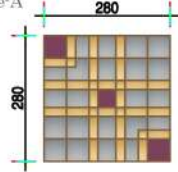

Module-A

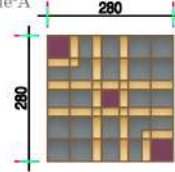

28 x 28 cm  
0.079 m<sup>2</sup> 13 PL / 1m<sup>2</sup>

11" x 11" inch  
1Pc = 0.85 Sqft

Module-B

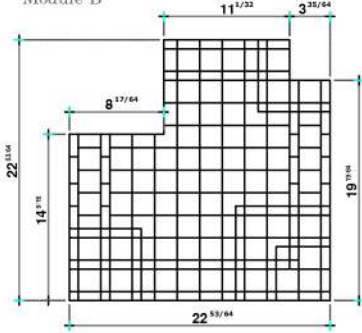

Module-B

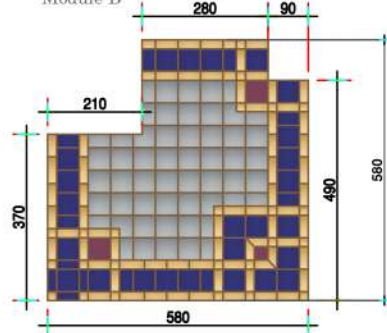

Module-B

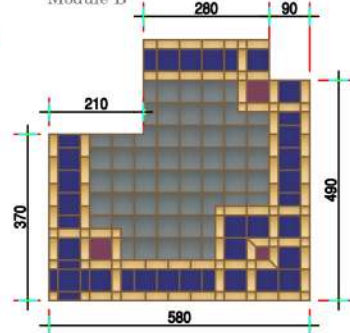

58 x 58 cm  
0.29 m<sup>2</sup> 3.5 PL / 1m<sup>2</sup>

22 1/22 x 22 1/22 inch  
1Pc = 3.12 Sqft



## Instruction de montage Mounting Instructions

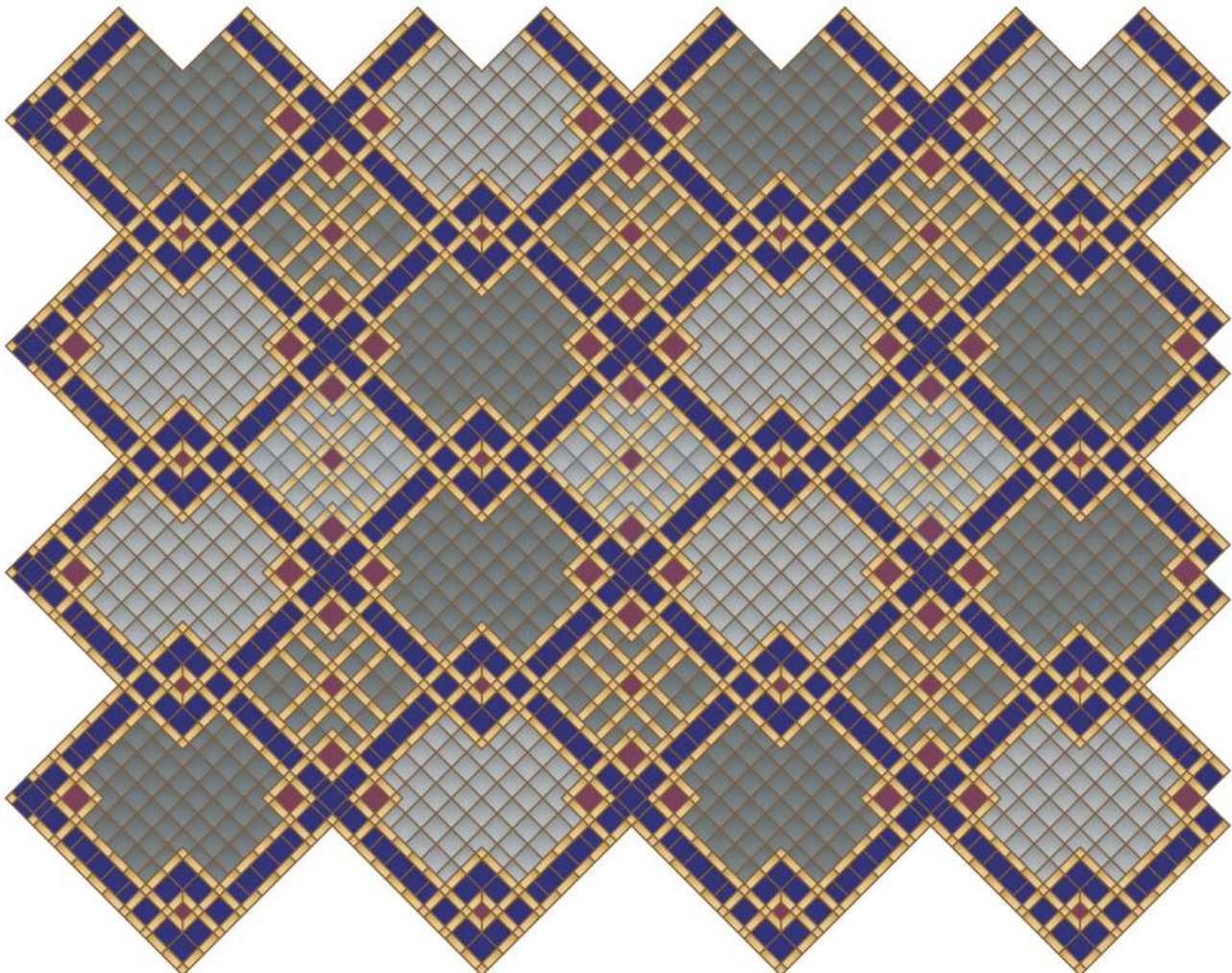

*THE ESSENTIALS*

---

**Borders**

Alfa

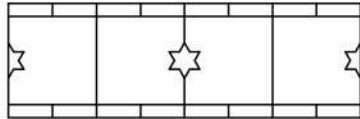

13 cm  
5<sup>1/8</sup> inch

Diaf

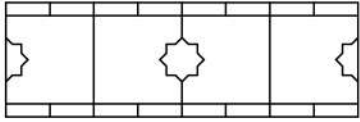

13 cm  
5<sup>1/8</sup> inch

Salmon

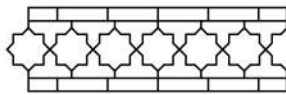

9.5 cm  
3<sup>7/8</sup> inch

Agadir

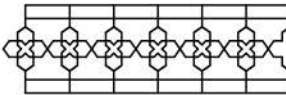

10 cm  
4 inch

Zahra

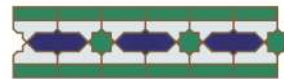
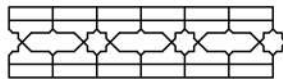

8 cm  
3<sup>1/2</sup> inch

Ifni

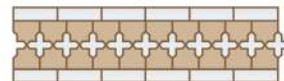
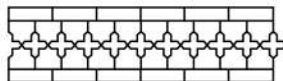

8.5 cm  
3<sup>3/4</sup> inch

Jasmin

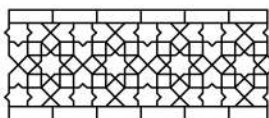

12.5 cm  
5 inch

Zagora

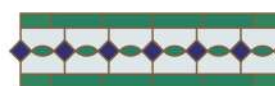
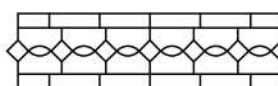

8.5 cm  
3<sup>3/4</sup> inch





Mazagan

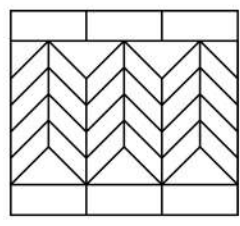

27 cm  
10<sup>9</sup>/<sub>8</sub> inch

Safi

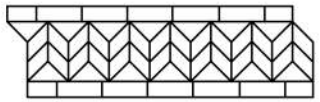

10 cm  
4 inch

Asilah

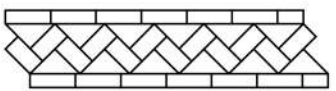

8.5 cm  
3<sup>1</sup>/<sub>4</sub> inch

Chaouen

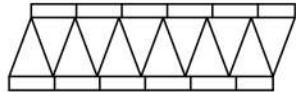

9.5 cm  
3<sup>4</sup>/<sub>8</sub> inch

Oujda

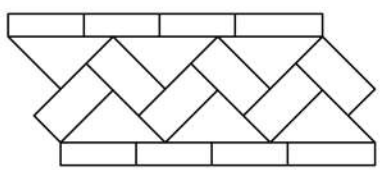

20 cm  
7<sup>7</sup>/<sub>8</sub> inch

Mogador

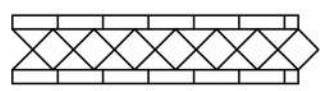

7.5 cm  
3 inch

Mogador Bis

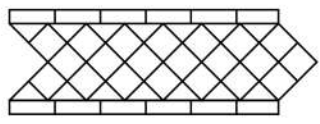

11.5 cm  
4<sup>17</sup>/<sub>32</sub> inch



Sefrou

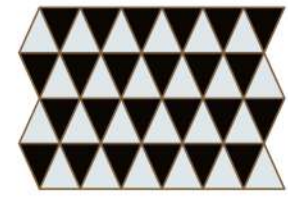
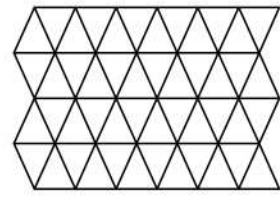

20 cm  
7<sup>7/8</sup> inch

Réfrafe

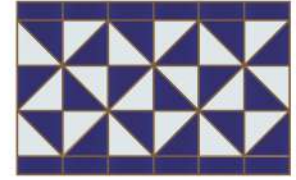
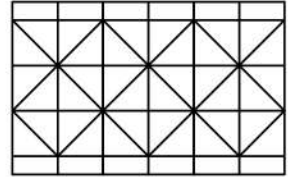

19 cm  
7<sup>15/32</sup> inch

Méchouar

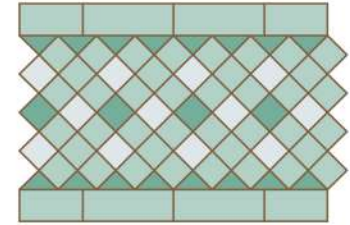
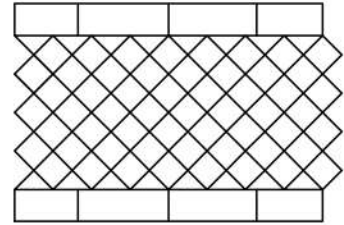

24 cm  
9<sup>7/16</sup> inch

Taourirt

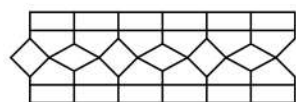

10 cm  
4 inch

Jeda

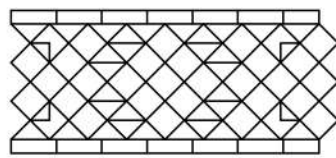

15.8 cm  
6<sup>7/32</sup> inch

Anfa

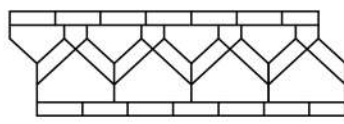

11.5 cm  
4<sup>17/32</sup> inch



Sevilla

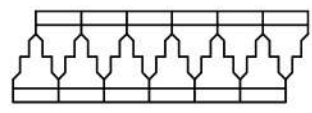

10 cm  
4 inch

Palmeraie

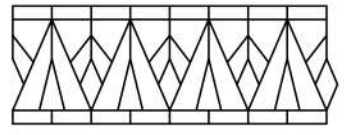

13 cm  
5<sup>1/8</sup> inch

Berber

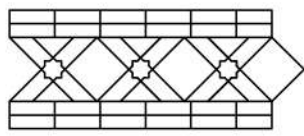

13 cm  
5<sup>1/8</sup> inch

Imilchil

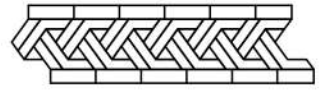

8.6 cm  
3<sup>25/64</sup> inch

Kasbah

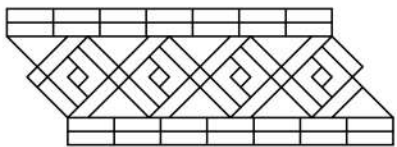

15 cm  
5<sup>29/32</sup> inch

Saidia

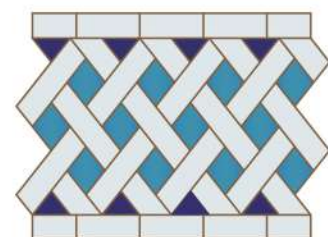
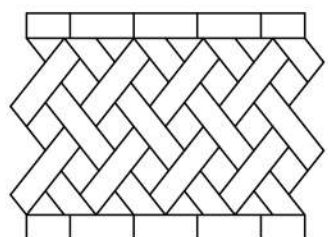

25 cm  
9<sup>27/32</sup> inch

Meknes

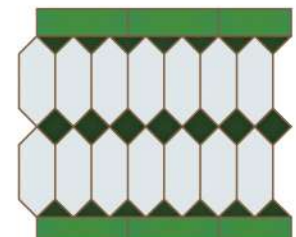
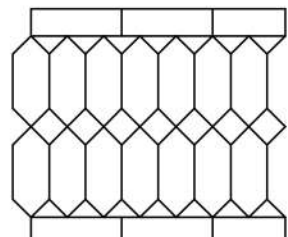

26 cm  
26<sup>10/64</sup> inch



*THE ESSENTIALS*

---

Loose pieces

Asni			20 x 10 cm 1m <sup>2</sup> =50 pc  8 x 4 inch 1Sqft = 4.5 Pc
Sebta Markab			10 x 10 cm 1m <sup>2</sup> =100 pc  4 x 4 inch 1Sqft = 9 Pc
Thalia			5 x 10 cm 1m <sup>2</sup> =10 pc  1 <sup>31/32</sup> x 3 <sup>15/16</sup> inch 1Sqft = 18 Pc
Bejmat bricks	 	 	14 x 14.5 x 1.8 cm 1m <sup>2</sup> =150 pc  5 <sup>23/32</sup> x 1 <sup>25/32</sup> x 23/32 inch 1Sqft = 14 Pc
Cabochons Gueliz			5 x 5 cm 1m <sup>2</sup> =400 pc  1 <sup>31/32</sup> x 1 <sup>31/32</sup> inch 1Sqft = 37 Pc
Cabochons Agdal			3.5 x 3.5 cm 1m <sup>2</sup> =840 pc  1 <sup>3/8</sup> x 1 <sup>3/8</sup> inch 1Sqft = 78 Pc
Ksira			2 x 5 cm 1m <sup>2</sup> =20 pc  25/32"x1 <sup>31/32</sup> inch 1Lnft = 7 Pc

Pièces taillées en biseau pour bordures

Special cutting for edges finishings



Kora & Cabochons



10 x 10 cm / 3.5x3.5cm  
4 x 4 inch / 1<sup>3/16</sup> x 1<sup>3/16</sup> inch  
1Sqft = 9 Pc  
+9pc Inset Agdal

Almas Diamond



14.5 x 14.5 cm  
1m<sup>2</sup> = 168 pc  
5<sup>5/64</sup> x 3<sup>5/16</sup> inch  
1Sqft = 16 Pc

Hexagone Santos



15 x 9 cm  
1m<sup>2</sup> = 97 pc  
5<sup>29/32</sup> x 3<sup>35/64</sup> inch  
1Sqft = 9 Pc

Hexagone Yunus



10 x 8.7 cm  
1m<sup>2</sup> = 154 pc  
4 x 3<sup>37/64</sup> inch  
1Sqft = 14 Pc

Aklim liner



20 x 20 x 1.5 cm  
1ml = 5 pc  
8" x 6/8 x 1/2 inch  
1Lnft = 1.5 Pc

Bullnose



10 x 10 cm  
5 x 10 cm  
1ml = 10 pc  
4 x 4 inch  
2 x 4 inch  
1Lnft = 3 Pc

Malak



7.5 x 7.5 cm  
1m<sup>2</sup> = 180 pc  
90A + 90B  
2<sup>10/16</sup> x 2<sup>10/16</sup> inch  
1Sqft = 16 Pc  
8A + 8B

Motif à 2 carreaux

Motif à 2 carreaux



Andalusia

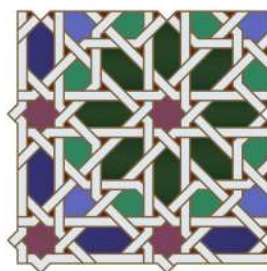
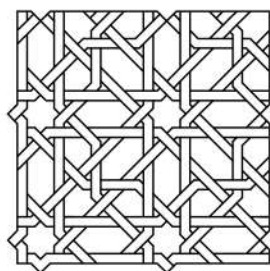

30 x 30 cm  
0.09 m<sup>2</sup> 11 PL / 1m<sup>2</sup>

11<sup>13/16</sup> x 11<sup>13/16</sup> inch  
1Pc = 1Sqft

Jerada

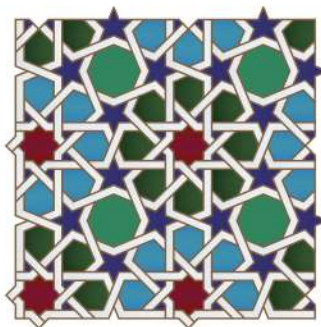
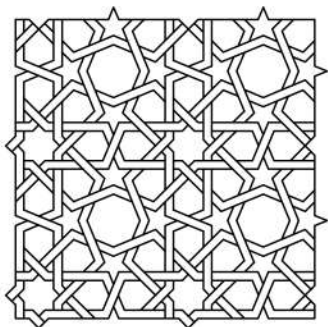

35.6 x 35.6 cm  
0.1265 m<sup>2</sup> 8 PL / 1m<sup>2</sup>

14<sup>6/16</sup> x 14<sup>6/16</sup> inch  
1Pc = 1.36 Sqft

Lqliâa

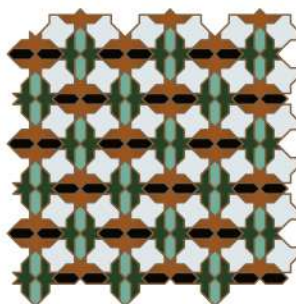
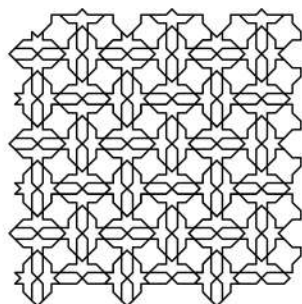

32 x 32 cm  
0.1 m<sup>2</sup> 10 PL / 1m<sup>2</sup>

12<sup>19/32</sup> x 12<sup>19/32</sup> inch  
1Pc = 1Sqft

Tamuda

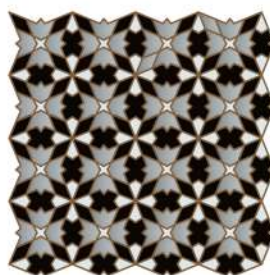
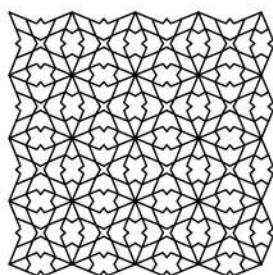

30 x 30 cm  
0.09 m<sup>2</sup> 11 PL / 1m<sup>2</sup>

11<sup>13/16</sup> x 11<sup>13/16</sup> inch  
1Pc = 1Sqft

Selouane

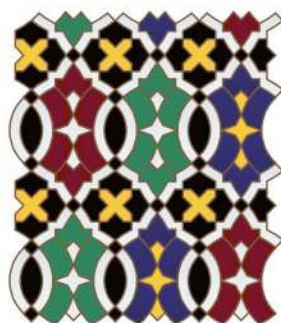
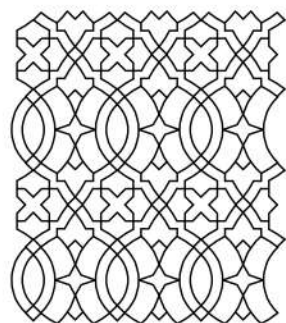

29.9 x 35.8 cm  
0.108 m<sup>2</sup> 9.25 PL / 1m<sup>2</sup>

11<sup>14/16</sup> x 14<sup>3/32</sup> inch  
1Pc = 1.16 Sqft





*THE CLASSICS*

---

Patterns

Andalusia Bis

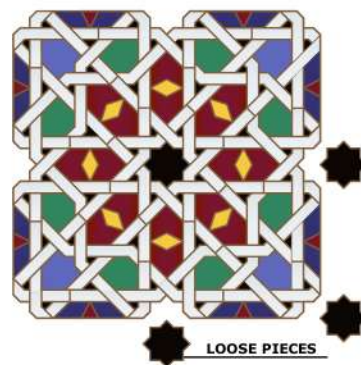
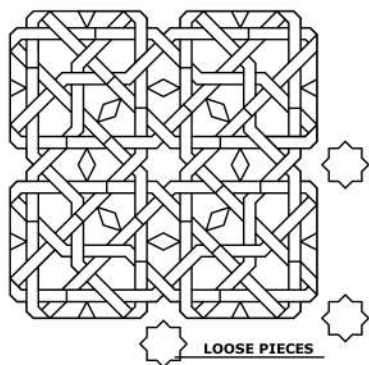

50 x 50 cm  
0.25 m<sup>2</sup> 4 PL / 1m<sup>2</sup>

19<sup>1/16</sup> x 19<sup>1/16</sup> inch  
1Pc = 2.7Sqft

Tinghir

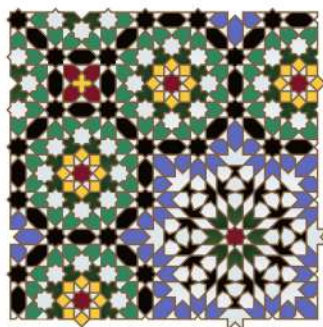
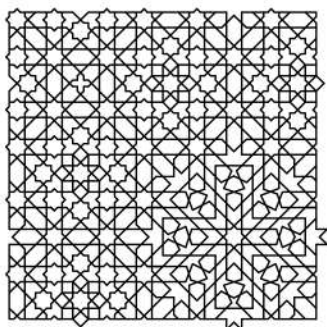

50 x 50 cm  
0.25 m<sup>2</sup> 4 PL / 1m<sup>2</sup>

19<sup>1/16</sup> x 19<sup>1/16</sup> inch  
1Pc = 2.7 Sqft

Bandar

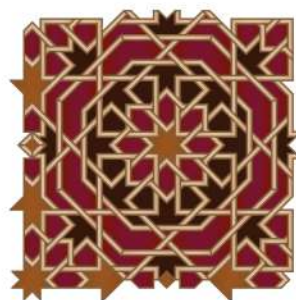
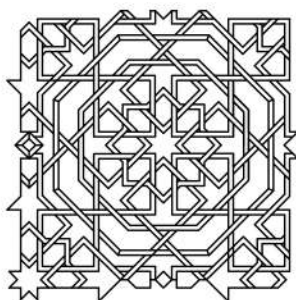

44 x 44 cm  
0.2 m<sup>2</sup> 5 PL / 1m<sup>2</sup>

17<sup>5/16</sup> x 17<sup>5/16</sup> inch  
1Pc = 2.2 Sqft

Boulmane

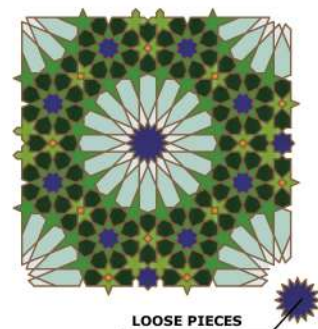
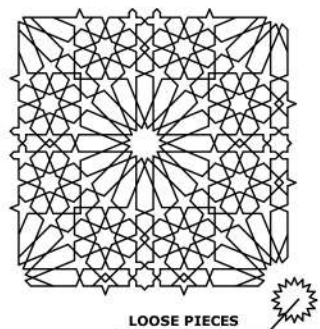

43.8 x 43.8 cm  
0.192 m<sup>2</sup> 5.5 PL / 1m<sup>2</sup>

17<sup>1/4</sup> x 17<sup>1/4</sup> inch  
1Pc = 2Sqft

Rif

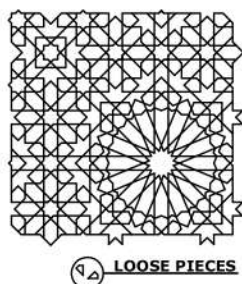

32.4 x 32.4 cm  
0.105 m<sup>2</sup> 10 PL / 1m<sup>2</sup>

12<sup>3/4</sup> x 12<sup>3/4</sup> inch  
1Pc = 1.1 Sqft

Ksar

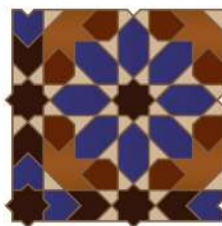
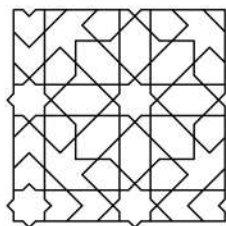

25 x 25 cm  
0.063 m<sup>2</sup> 16 PL / 1m<sup>2</sup>

9<sup>27/32</sup> x 9<sup>27/32</sup> inch  
1Pc = 0.68 Sqft

Ksar Bis

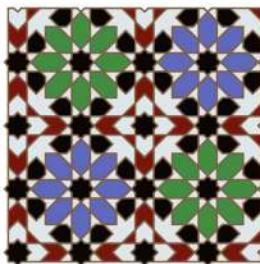
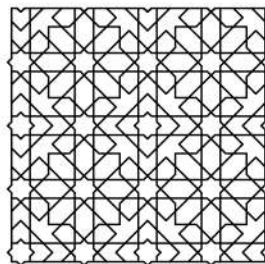

30 x 30 cm  
0.09 m<sup>2</sup> 11 PL / 1m<sup>2</sup>

11<sup>13/16</sup> x 11<sup>13/16</sup> inch  
1Pc = 1 Sqft

Oulmes

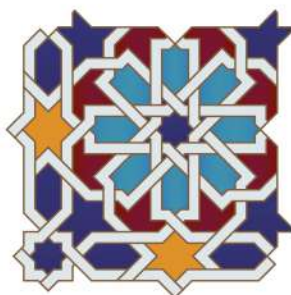
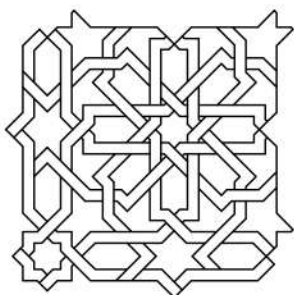

30 x 30 cm  
0.09 m<sup>2</sup> 11 PL / 1m<sup>2</sup>

11<sup>13/16</sup> x 11<sup>13/16</sup> inch  
1Pc = 1 Sqft

Azilal

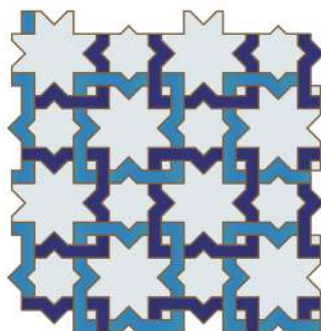
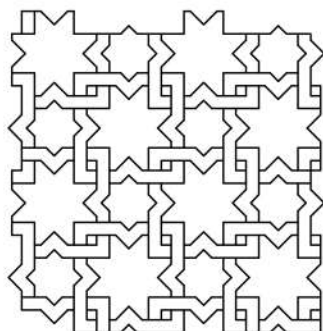

35.5 x 35.5 cm  
0.125 m<sup>2</sup> 8 PL / 1m<sup>2</sup>

13<sup>29/32</sup> x 13<sup>29/32</sup> inch  
1Pc = 1.35Sqft

Almarzouke

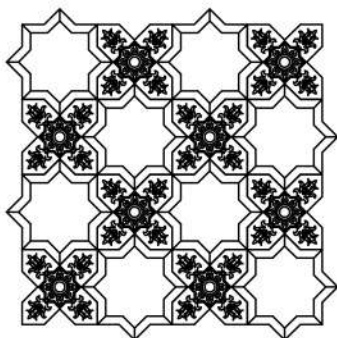

35.5 x 35.5 cm  
0.126 m<sup>2</sup> 8 PL / 1m<sup>2</sup>

13<sup>31/32</sup> x 13<sup>31/32</sup> inch  
1Pc = 1.4Sqft

Farah

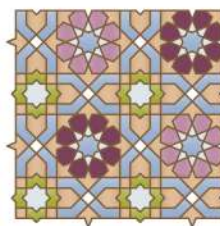
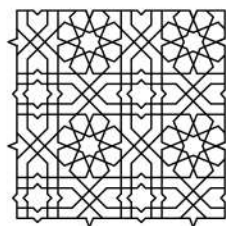

30 x 30 cm  
0.09 m<sup>2</sup> 11 PL / 1m<sup>2</sup>

11<sup>13/16</sup> x 11<sup>13/16</sup> inch  
1Pc = 1Sqft

Privée

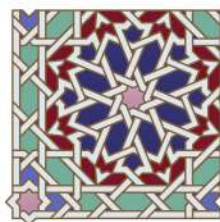
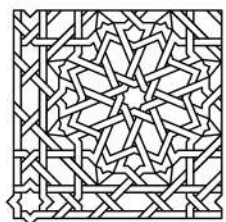

35.6 x 35.6 cm  
0.1265 m<sup>2</sup> 8 PL / 1m<sup>2</sup>

11<sup>13/16</sup> x 11<sup>13/16</sup> inch  
1Pc = 1 Sqft

Darje

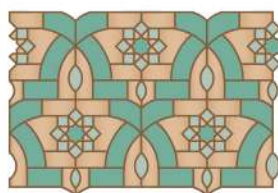
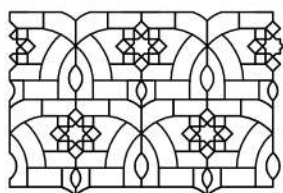

38 x 25.2 cm  
0.96 m<sup>2</sup> 10.5 PL / 1m<sup>2</sup>

14<sup>51/64</sup> x 9<sup>59/64</sup> inch  
1Pc = 1Sqft

El Kelaa

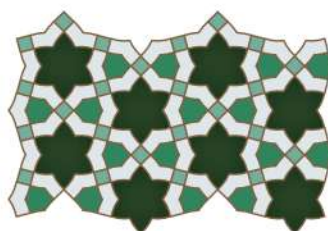
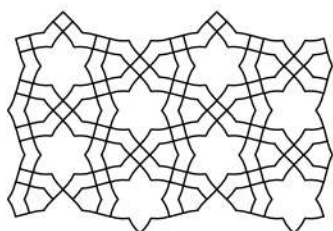

44.5 x 25.7 cm  
0.114 m<sup>2</sup> 9 PL / 1m<sup>2</sup>

17<sup>7/32</sup> x 10<sup>9/16</sup> inch  
1Pc = 1.2 Sqft

Alhambra

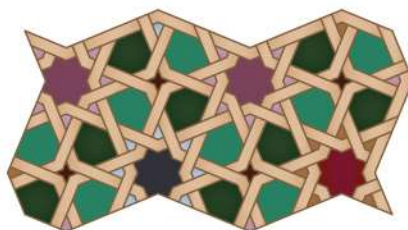
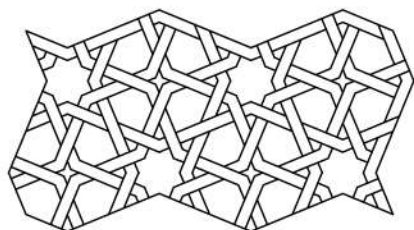

53 x 26.5 cm  
0.14 m<sup>2</sup> 8 PL / 1m<sup>2</sup>

20<sup>7/8</sup> x 10<sup>7/16</sup> inch  
1Pc = 1.5 Sqft



Dades

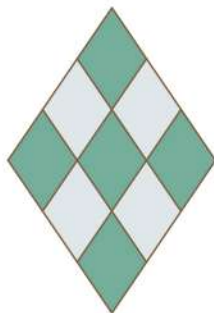
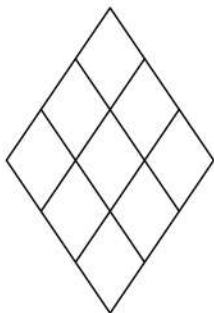

43.4 x 29.5 cm  
0.064 m<sup>2</sup> 16 PL / 1m<sup>2</sup>

17<sup>3/32</sup> x 11<sup>39/64</sup> inch  
1Pc = 0.7 Sqft

Darmala

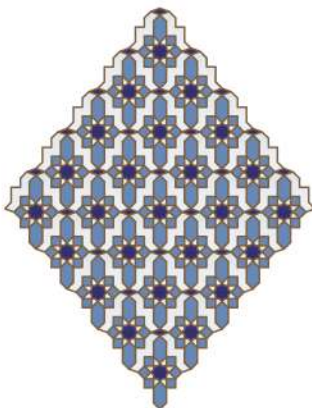
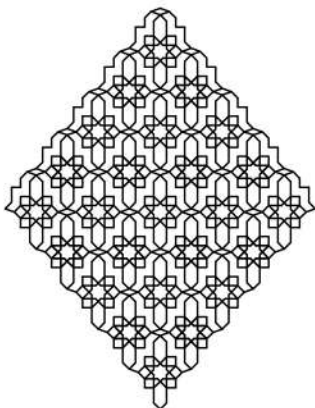

57 x 44 cm  
0.126 m<sup>2</sup> 8 PL / 1m<sup>2</sup>

22<sup>7/16</sup> x 17<sup>5/16</sup> inch  
1Pc = 1.35 Sqft

Sakir

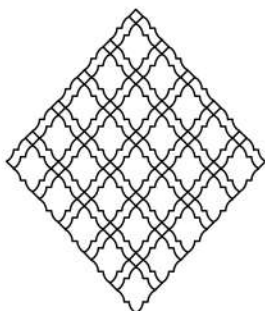

43.2 x 36.8 cm  
0.08 m<sup>2</sup> 12.5 PL / 1m<sup>2</sup>

17<sup>1/64</sup> x 14<sup>31/64</sup> inch  
1Pc = 0.85 Sqft

Zemmour

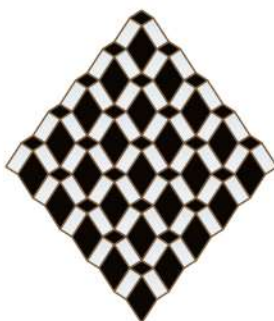
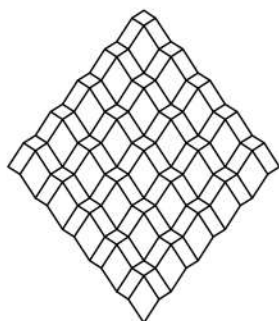

44.4 x 38.6 cm  
0.086 m<sup>2</sup> 12 PL / 1m<sup>2</sup>

17<sup>31/64</sup> x 15<sup>13/64</sup> inch  
1Pc = 0.93 Sqft

Risani

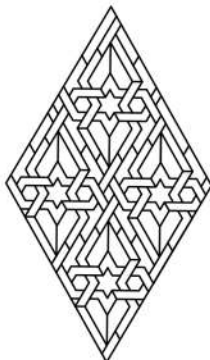

50.6 x 29.2 cm  
0.074 m<sup>2</sup> 13.5 PL / 1m<sup>2</sup>

19<sup>59/64</sup> x 11<sup>1/2</sup> inch  
1Pc = 0.8 Sqft



Nador

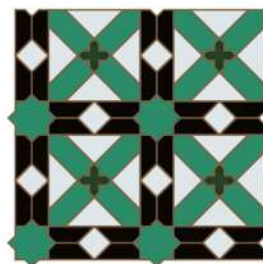
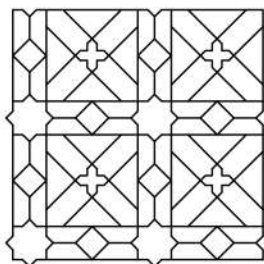

30 x 30 cm  
0.09 m<sup>2</sup> 11 PL / 1m<sup>2</sup>

11<sup>13/16</sup> x 11<sup>13/16</sup> inch  
1Pc = 1Sqft

Tan Tan

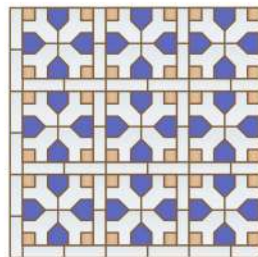
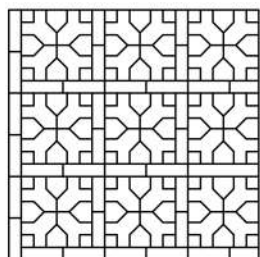

30 x 30 cm  
0.09 m<sup>2</sup> 11 PL / 1m<sup>2</sup>

11<sup>13/16</sup> x 11<sup>13/16</sup> inch  
1Pc = 1Sqft

Larache

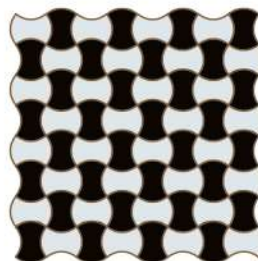
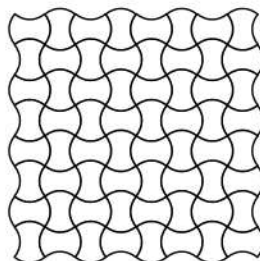

29.2 x 29.2 cm  
0.085 m<sup>2</sup> 12 PL / 1m<sup>2</sup>

11<sup>1/2</sup> x 11<sup>1/2</sup> inch  
1Pc = 1Sqft

Tarfaya

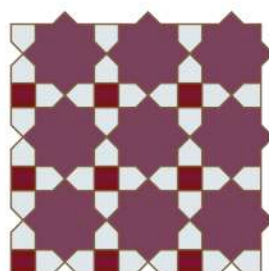
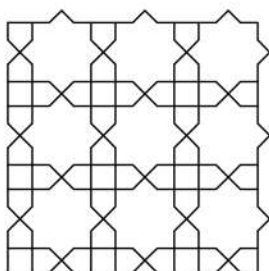

30 x 30 cm  
0.09 m<sup>2</sup> 11 PL / 1m<sup>2</sup>

11<sup>13/16</sup> x 11<sup>13/16</sup> inch  
1Pc = 1Sqft

Figuig

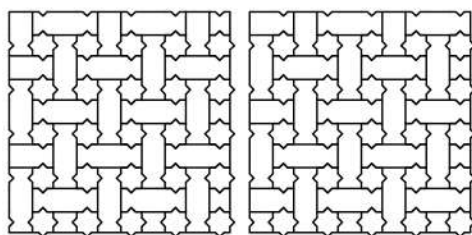

Module-A

Module-B

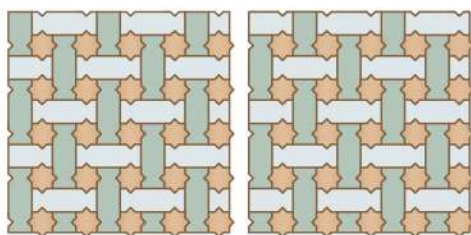

Module-A

Module-B

31.8 x 31.8 cm  
0.101 m<sup>2</sup> 10 PL / 1m<sup>2</sup>

12<sup>7/32</sup> x 12<sup>7/32</sup> inch  
1Pc = 1.1 Sqft



Amgala

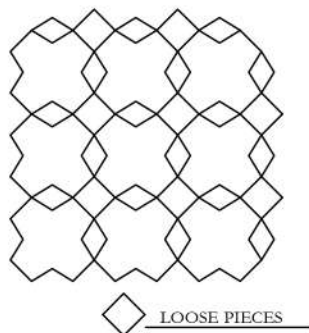

30 x 30 cm  
0.09 m<sup>2</sup> 11 PL / 1m<sup>2</sup>

11<sup>13/16</sup> x 11<sup>13/16</sup> inch  
1Pc = 1Sqft



Jennane

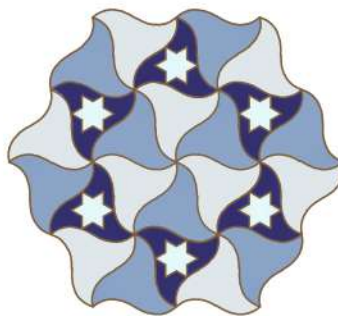
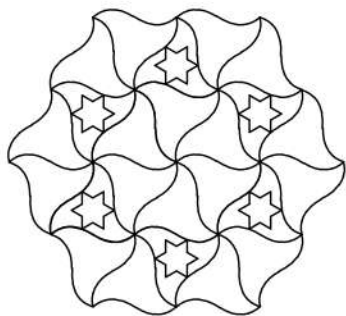

41 x 41 cm  
0.104 m<sup>2</sup> 10 PL / 1m<sup>2</sup>

16<sup>5/8</sup> x 16<sup>5/8</sup> inch  
1Pc = 1.1 Sqft

Smara

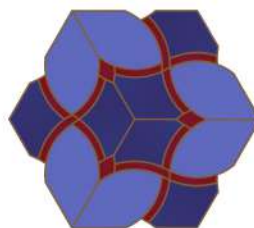
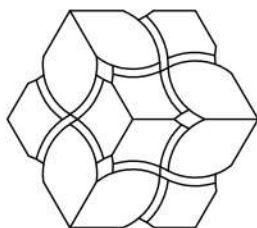

26 x 30 cm  
0.057 m<sup>2</sup> 18 PL / 1m<sup>2</sup>

10<sup>1/4</sup> x 11<sup>15/16</sup> inch  
1Pc = 0.6 Sqft

Maaziz

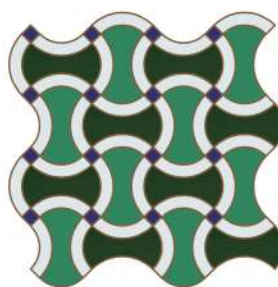
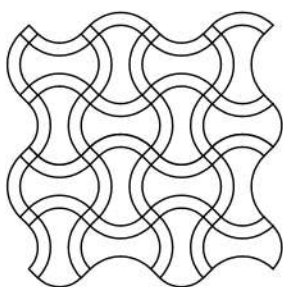

29.2 x 29.2 cm  
0.086 m<sup>2</sup> 12 PL / 1m<sup>2</sup>

11<sup>1/2</sup> x 11<sup>1/2</sup> inch  
1Pc = 1Sqft

Mirlefta

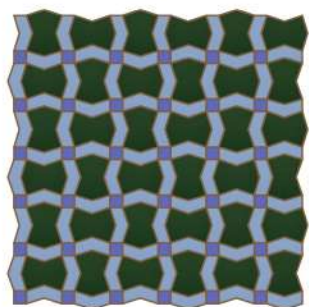
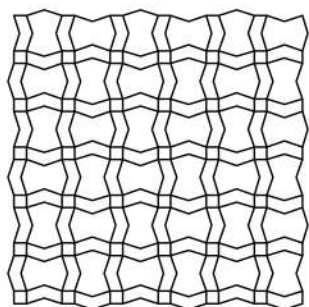

34.5 x 34.5 cm  
0.1189 m<sup>2</sup> 9 PL / 1m<sup>2</sup>

13<sup>10/32</sup> x 13<sup>10/32</sup> inch  
1Pc = 1.1 Sqft



Jeda

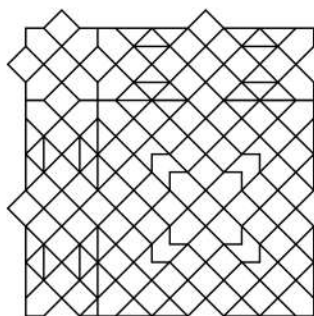

34 x 34 cm  
0.1156 m<sup>2</sup> 9 PL / 1m<sup>2</sup>

13<sup>3/8</sup> x 13<sup>3/8</sup> inch  
1Pc = 1.25 Sqft

Boujdour

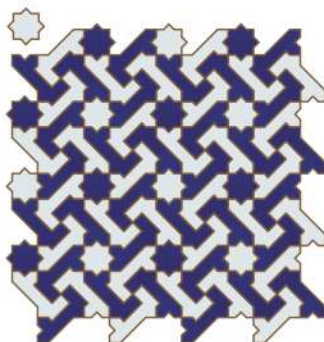
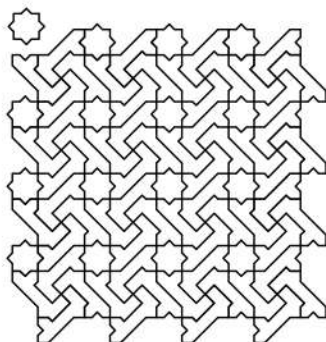

34 x 34 cm  
0.116 m<sup>2</sup> 9 PL / 1m<sup>2</sup>

13<sup>5/8</sup> x 13<sup>5/8</sup> inch  
1Pc = 1.3 Sqft

Azur

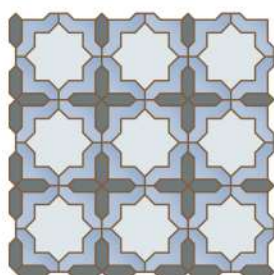
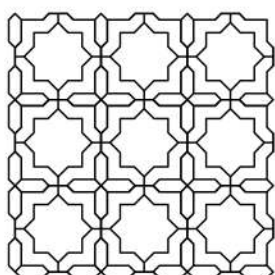

30 x 30 cm  
0.09 m<sup>2</sup> 11 PL / 1m<sup>2</sup>

11<sup>13/16</sup> x 11<sup>13/16</sup> inch  
1Pc = 1Sqft

Fez

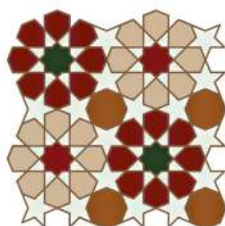
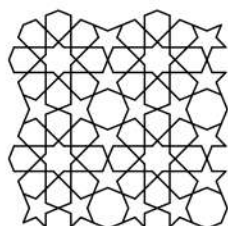

23.3 x 23.3 cm  
0.544 m<sup>2</sup> 19 PL / 1m<sup>2</sup>

9<sup>5/32</sup> x 9<sup>5/32</sup> inch  
1Pc = 0.6 Sqft

Massa

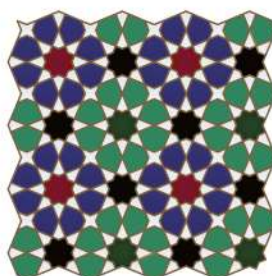
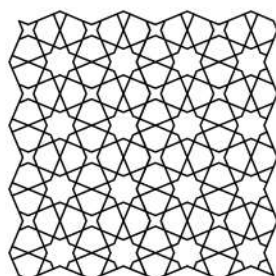

30 x 30 cm  
0.09 m<sup>2</sup> 11 PL / 1m<sup>2</sup>

11<sup>13/16</sup> x 11<sup>13/16</sup> inch  
1Pc = 1Sqft

▶ **LOOSE PIECES**

▶ **LOOSE PIECES**



*THE CLASSICS*

---

**Borders**



Ifrane

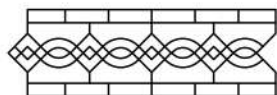

10 cm  
4 inch

Zahia

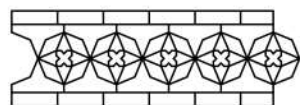

11 cm  
4<sup>1</sup>/<sub>4</sub> inch

Olfa

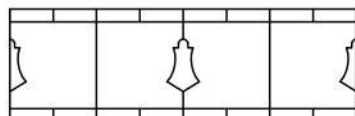

13 cm  
5<sup>1</sup>/<sub>8</sub> inch

Sharafa

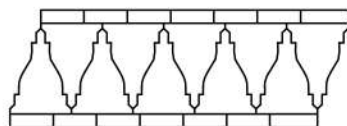

13.5 cm  
5<sup>3</sup>/<sub>16</sub> inch

Sharafa Zigzag

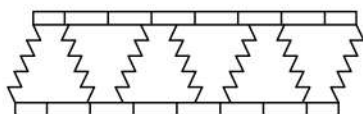

12 cm  
4<sup>23</sup>/<sub>32</sub> inch

Zat

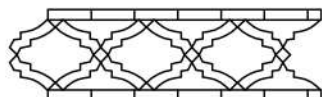

10.5 cm  
4<sup>1</sup>/<sub>8</sub> inch

Hilal

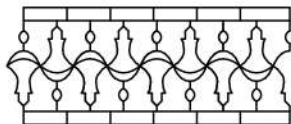

13.5 cm  
5<sup>3</sup>/<sub>16</sub> inch

Kairouan

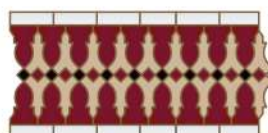
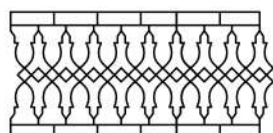

14.5 cm  
5<sup>49</sup>/<sub>64</sub> inch

Bandar

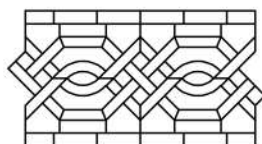

15.6 cm  
6<sup>9</sup>/<sub>64</sub> inch



Lixus

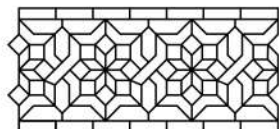

17 cm  
6<sup>11/16</sup> inch

Houceima

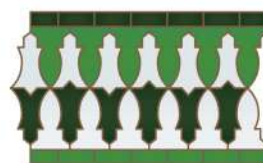
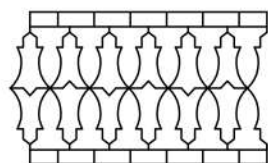

21 cm  
8<sup>9/32</sup> inch

Ketama

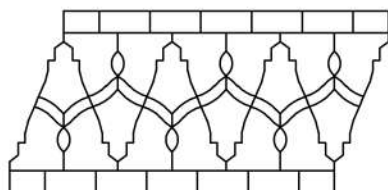

25 cm  
9<sup>7/32</sup> inch

Mediouna

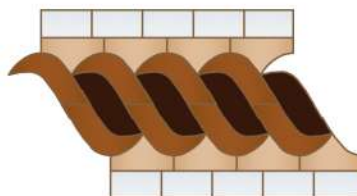
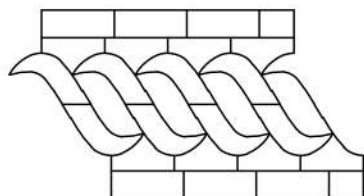

26 cm  
10<sup>15/64</sup> inch

Oasis

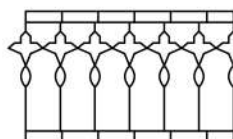

18 cm  
7<sup>1/8</sup> inch

Kenitra

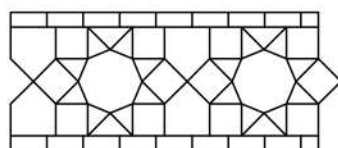

19 cm  
7<sup>15/32</sup> inch

Hassania

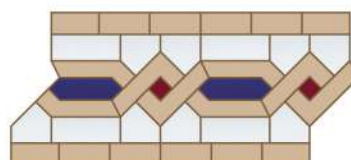
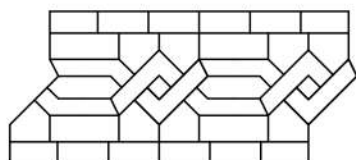



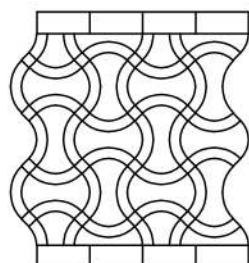

21 cm  
8<sup>9/32</sup> inch

Maaziz

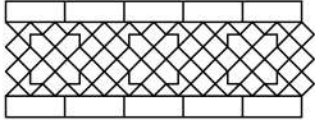

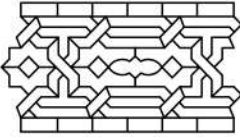
35 cm  
13<sup>25/32</sup> inch

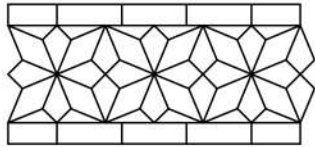
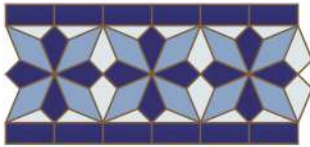
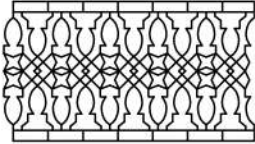
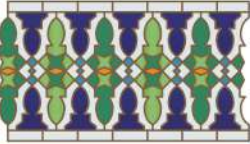
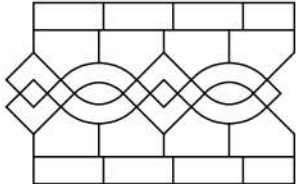
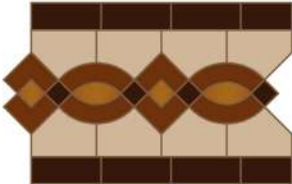
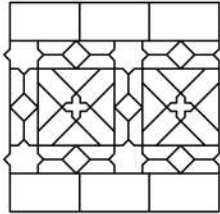
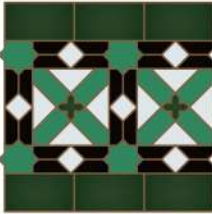
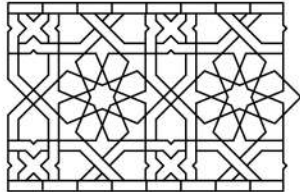
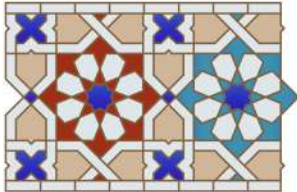
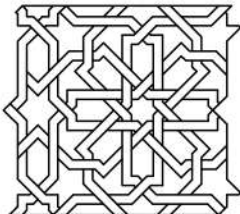
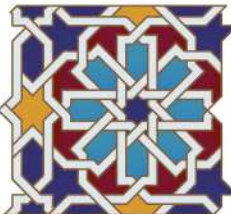
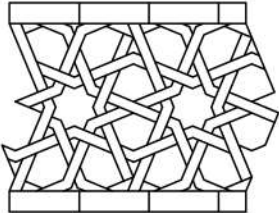
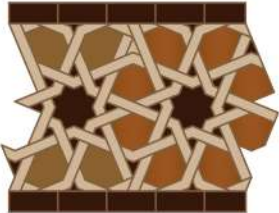
Zarhoune			17 cm 6 <sup>11/16</sup> inch
Zaio			18.5 cm 7 <sup>9/32</sup> inch
Tinmel			20 cm 7 <sup>7/8</sup> inch
Sultan			20 cm 7 <sup>7/8</sup> inch
Cordoba			26 cm 10 <sup>5/16</sup> inch
Nador			30 cm 11 <sup>13/16</sup> inch
Al-Fida			27 cm 10 <sup>9/16</sup> inch
Oulmes			30 cm 11 <sup>13/16</sup> inch
Andalus			30 cm 11 <sup>13/16</sup> inch



Dfira

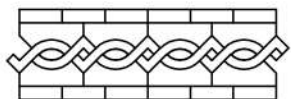

10 cm  
4 inch

Ait Imi

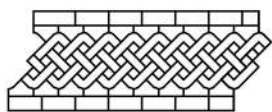

11 cm  
4<sup>1/4</sup> inch

Borj

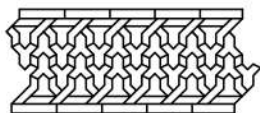

11.5 cm  
4<sup>17/92</sup> inch

Hassane

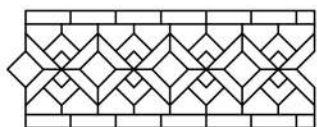

13 cm  
5<sup>1/8</sup> inch

Casablanca

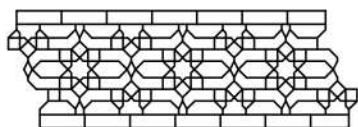

13 cm  
5<sup>1/8</sup> inch

Chichaoua

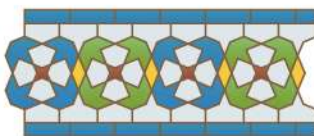
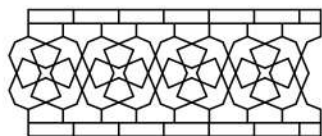

14 cm  
5<sup>33/64</sup> inch

Targa

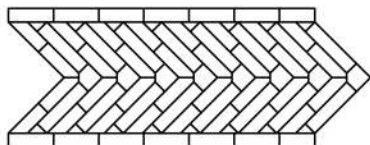

15.4 cm  
6<sup>1/8</sup> inch

Fez

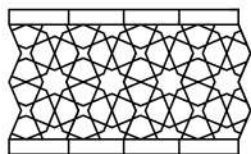

16 cm  
6<sup>5/16</sup> inch

Hammam

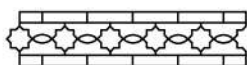

6 cm  
2<sup>3/8</sup> inch





*THE CLASSICS*

---

Chiseled



### Imouzzer

Motif à 4 carreaux  
4 tiles patterns

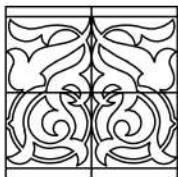

10 x 10 cm  
3<sup>15/16</sup> x 3<sup>15/16</sup> inch

### Imlil

Motif à 4 carreaux  
4 tiles patterns



10 x 10 cm  
3<sup>15/16</sup> x 3<sup>15/16</sup> inch

### Khmissa

Motif à 4 carreaux  
4 tiles patterns

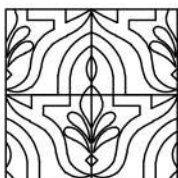

10 x 10 cm  
3<sup>15/16</sup> x 3<sup>15/16</sup> inch

### Coquillage-Shell



10 x 10 cm  
3<sup>15/16</sup> x 3<sup>15/16</sup> inch

### Palma



10 x 10 cm  
3<sup>15/16</sup> x 3<sup>15/16</sup> inch

### Iris



10 x 10 cm  
3<sup>15/16</sup> x 3<sup>15/16</sup> inch

### Poisson- Ocean

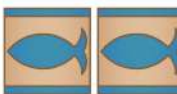
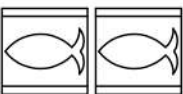

10 x 10 cm  
3<sup>15/16</sup> x 3<sup>15/16</sup> inch

### Argana



10 x 10 cm  
3<sup>15/16</sup> x 3<sup>15/16</sup> inch

### Petra



10 x 10 cm  
3<sup>15/16</sup> x 3<sup>15/16</sup> inch

### Berkane



10 x 10 cm  
3<sup>15/16</sup> x 3<sup>15/16</sup> inch

Azrou



10 x 10 cm  
 $3^{15/16}$  x  $3^{15/16}$  inch

Imzour



10 x 10 cm  
 $3^{5/16}$  x  $3^{15/16}$  inch

Tazarine



10 x 10 cm  
 $3^{15/16}$  x  $3^{15/16}$  inch

Nejma

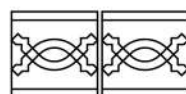

10 x 10 cm  
 $3^{5/16}$  x  $3^{15/16}$  inch

Tamaris

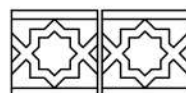

10 x 10 cm  
 $3^{5/16}$  x  $3^{15/16}$  inch

Oued Zem

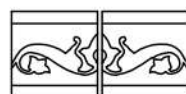

10 x 10 cm  
 $3^{15/16}$  x  $3^{15/16}$  inch

Azilal



10 x 10 cm  
 $3^{15/16}$  x  $3^{15/16}$  inch

Jorf

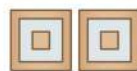
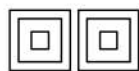

7 x 7 cm  
 $2^{3/4}$  x  $2^{3/4}$  inch

Bord Hana



10 x 3 cm  
 $3^{5/16}$  x  $1^{9/16}$  inch

Bord Arousa



10 x 4 cm  
 $3^{5/16}$  x  $1^{9/16}$  inch

Bord Riad



10 x 4.5 cm  
 $3^{5/16}$  x  $1^{25/32}$  inch

## *THE DESIGNS*

---

# Art Déco Collection

The Aït Manos Workshops travel back in time,  
to the heart of the 20s in Casablanca.

An exhilarating, flamboyant era, during which architects  
discovered the treasures of the Moorish heritage that they  
distilled into wildly elegant buildings. This is what Aït Manos  
interprets with “Art Deco”, a collection composed of 6 modules  
with rich patterns, orchestrated in 18-carat gold, black and  
white carrare.

Guelmim

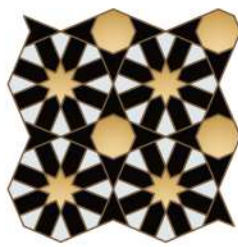
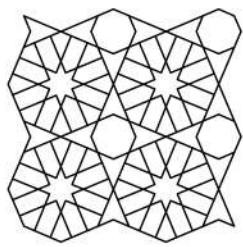

31 x 31 cm  
0.0922 m<sup>2</sup> 11 PL / 1m<sup>2</sup>

12<sup>3/16</sup> x 12<sup>3/16</sup> inch  
1Pc = 1 Sqft

Zayane

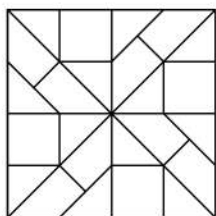

30 x 30 cm  
0.09 m<sup>2</sup> 11 PL / 1m<sup>2</sup>

11<sup>13/16</sup> x 11<sup>13/16</sup> inch  
1Pc = 1Sqft

Souss

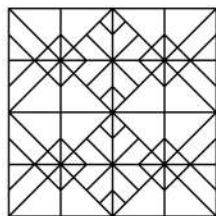

30 x 30 cm  
0.09 m<sup>2</sup> 11 PL / 1m<sup>2</sup>

11<sup>13/16</sup> x 11 inch  
1Pc = 1Sqft

Tata

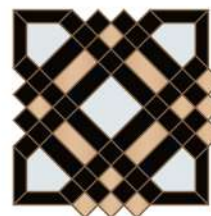
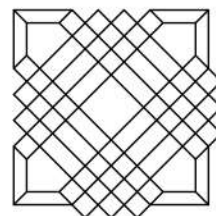

28.1 x 28.1 cm  
0.0791 m<sup>2</sup> 13 PL / 1m<sup>2</sup>

11<sup>3/8</sup> x 11<sup>3/8</sup> inch  
1Pc = 0.9 Sqft

Talet Bis

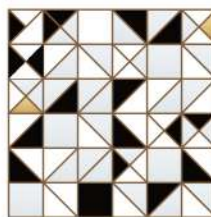
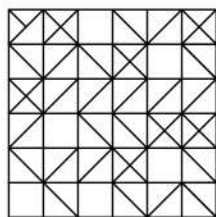

30 x 30 cm  
0.09 m<sup>2</sup> 11 PL / 1m<sup>2</sup>

11<sup>13/16</sup> x 11 inch  
1Pc = 1Sqft

Tichka

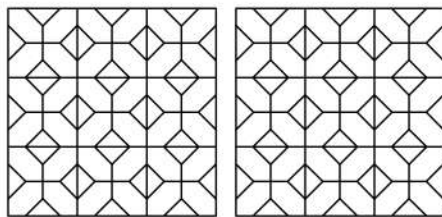

Module-A

Module-B

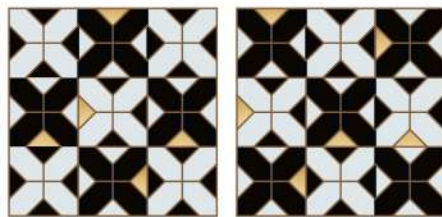

Module-A

Module-B

30 x 30 cm  
0.09 m<sup>2</sup> 11 PL / 1m<sup>2</sup>

11<sup>13/16</sup> x 11 inch  
1Pc = 1Sqft





*THE DESIGNS*

---

## Pikzel Collection

**Myriam Mourabit** 's original and delicate  
creations have brought her into light, brilliantly  
celebrating the happy marriage of Modern  
Design and Traditional Art with luminosity and poetry

## PIKZEL SUMMER

line - 7 is divided into two middle parts and the upper part is placed to the right of the bottom with 180 ° rotation

line - 6

line - 5

line - 4

line - 3

line - 2

line -1 is divided into two parts of the middle and the bottom is placed to the right of the top with 180 ° rotation

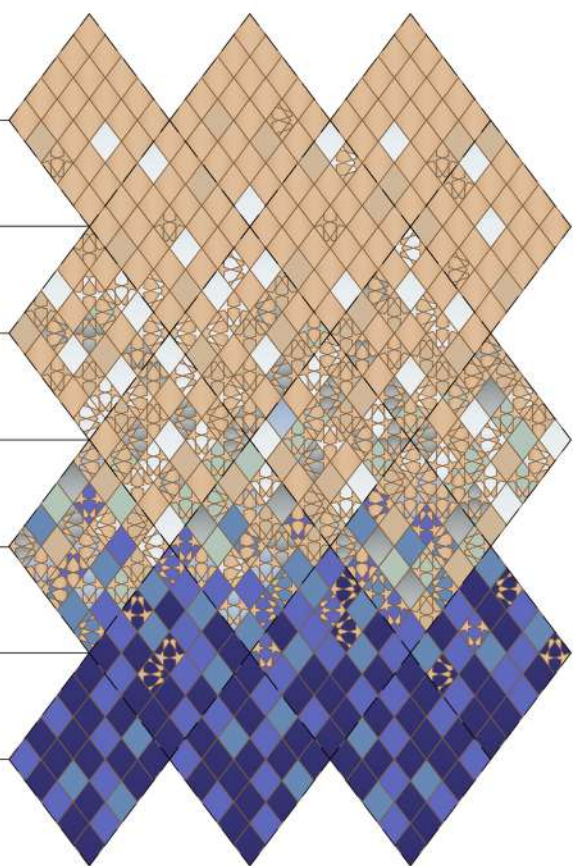

-  NATURAL
-  LAVA
-  WHITE
-  GREY CHINE
-  CELADON
-  ICE BLUE
-  SKY BLUE
-  LAVENDER BLUE
-  NAVY BLUE

## PIKZEL SPRING

line - 7 is divided into two middle parts and the upper part is placed to the right of the bottom with 180 ° rotation

line - 6

line - 5

line - 4

line - 3

line - 2

line -1 is divided into two parts of the middle and the bottom is placed to the right of the top with 180 ° rotation

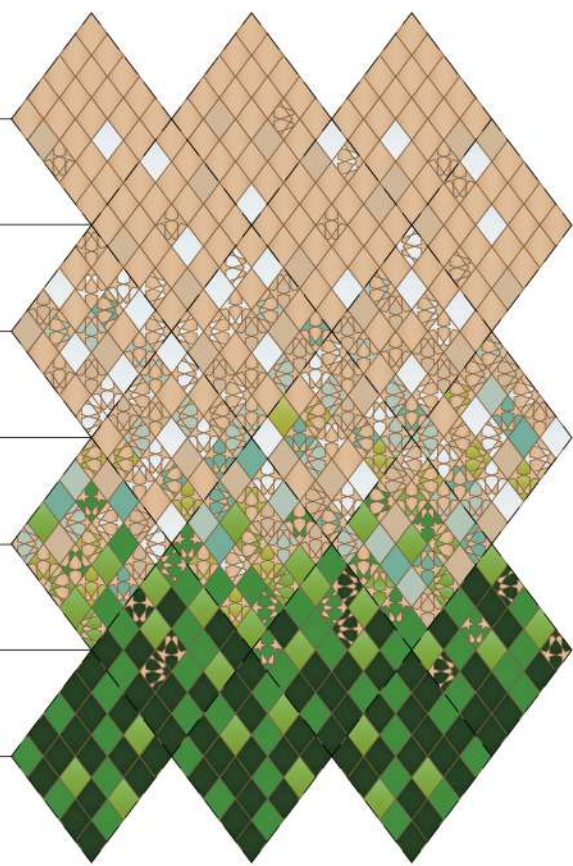

-  NATURAL
-  LAVA
-  WHITE
-  CELADON
-  AQUA GREEN
-  APPLE GREEN
-  PARSLEY
-  DARK PARSLEY
-  DARK GREEN

## PIKZEL SUMMER

line - 7 is divided into two middle parts and the upper part is placed to the right of the bottom with 180 ° rotation

line - 6

line - 5

line - 4

line - 3

line - 2

line -1 is divided into two parts of the middle and the bottom is placed to the right of the top with 180 ° rotation

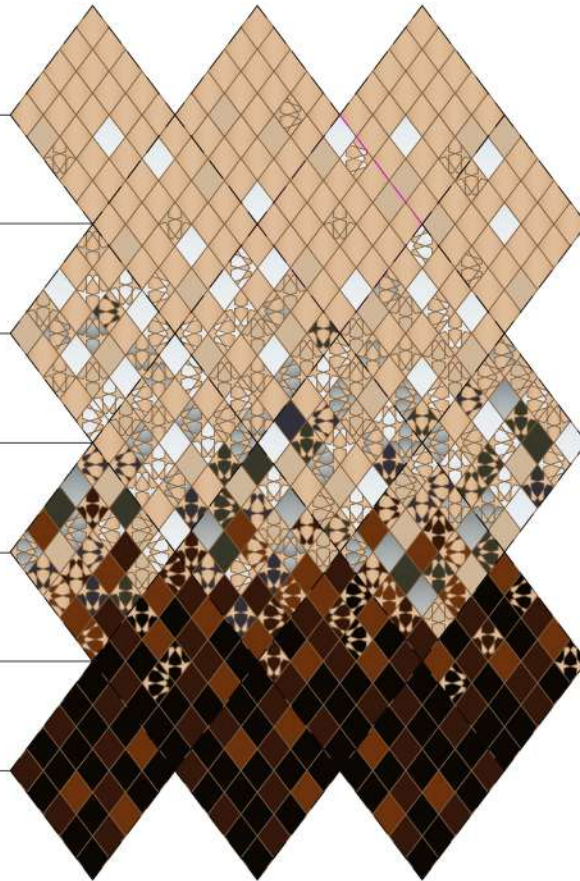

-  NATURAL
-  LAVA
-  WHITE
-  GREY CHINE
-  TAUPE
-  CHARCOAL GREY
-  BROWN
-  CHOCOLATE
-  BLACK

## PIKZEL SPRING

line - 7 is divided into two middle parts and the upper part is placed to the right of the bottom with 180 ° rotation

line - 6

line - 5

line - 4

line - 3

line - 2

line -1 is divided into two parts of the middle and the bottom is placed to the right of the top with 180 ° rotation

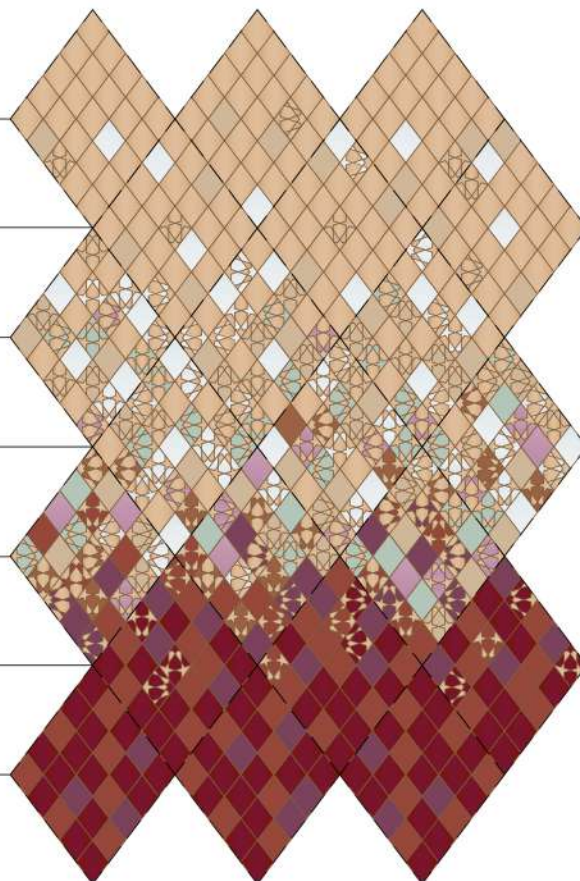

-  NATURAL
-  LAVA
-  WHITE
-  CELADON
-  PINK
-  SALMON
-  PURPLE
-  PEACH
-  RED





## *THE DESIGNS*

---

### Mirage

**Eric Gizard** is both a talented orchestrator and a visionary, drawing his inspiration and references from the mid-century modern. The unique signature is his work on emphatic contrasts and “light vs dark”.

# Mirage

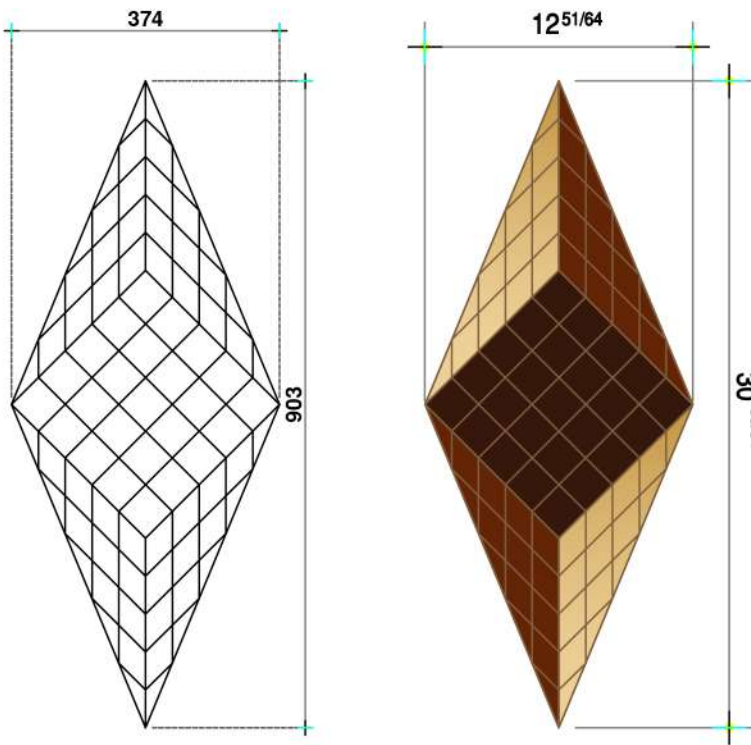

78.4 x 32.5 cm  
0.127 m<sup>2</sup> 8 PL / 1m<sup>2</sup>

30<sup>55/64</sup> x 12<sup>51/64</sup> inch  
1Pc = 1.37 Sqft





AITMANOS

ZELLIGE  
CASABLANCA

Shop online: [www.shop.aitmanos.com](http://www.shop.aitmanos.com) Website: [www.aitmanos.com](http://www.aitmanos.com)  
Instagram: [aitmanosmorocco](#) - Pinterest: [Aït Manos](#) -  
Facebook: [Aït Manos Zellige](#)

